

C-103-4 HANGER FOR C-104 OR C-108 TRACK

INSTRUCTION SHEET



PARTS LIST

C-103-4 HANGER
ASSEMBLED
(2 PER DOOR)

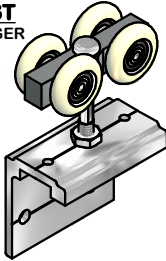

5/16"-18 X 2-1/2"
HEX BOLT
(2 PER HANGER)



5/16" HEX NUT
(2 PER HANGER)



5/16" PLAIN WASHER
(4 PER HANGER)



#10 X 1-1/2" SCREWS
(2 PER HANGER)



EXTRUDED
ALUMINUM TRACK

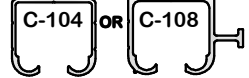

SPECIFICATIONS:

-LOAD CAPACITY:
200 LBS PER DOOR.

-DESIGNED FOR TOP
AND FACE MOUNTING
ON 1-3/4" DOORS.

-HEAVY-DUTY
PRECISION BALL
BEARING WHEELS
WITH NYLON TIRE.

-PROVIDES A SECURE
GRIP FOR HEAVY
LOADS.

-FOR BY-PASSING,
BI-PARTING, POCKET,
AND SURFACE
MOUNT/BARN STYLE
APPLICATIONS.

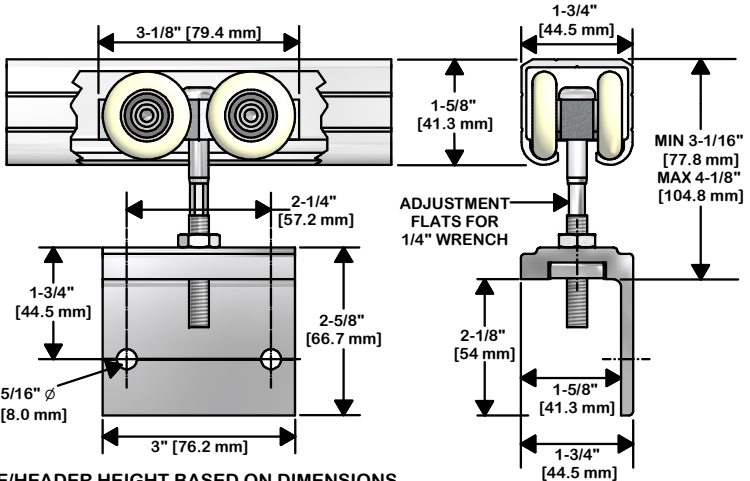

STEP 1

DETERMINE DOOR SIZE/HEADER HEIGHT BASED ON DIMENSIONS SHOWN IN DETAIL VIEWS AND CLEARANCE REQUIRED BELOW DOOR.

STEP 2

A) LOCATE CLEARANCE HOLE FOR HANGER STUD 4-1/2" FROM EACH EDGE OF DOOR AND 3/4" FROM BACK FACE OF DOOR. DRILL WITH 3/8"Ø BIT AT LEAST 1-1/2" DEEP. IF USING KNC CAS-2 DOOR STOP, LOCATE CLEARANCE HOLE 5-1/2" FROM EDGE OF DOOR.

B) CENTER TOP/SIDE PLATE OVER HOLE, MARK SCREW HOLE LOCATIONS AND PRE-DRILL WITH 1/8"Ø BIT AT LEAST 1-1/2" DEEP.

C) MARK AND DRILL 21/64"Ø SIDE HOLES THROUGH THE DOOR.

STEP 3

PREPARE DOOR FOR INSTALLATION OF OPTIONAL PRODUCTS IF PURCHASED SUCH AS GUIDE CHANNELS, CUP PULLS, DOOR LOCKS, ETC. INDIVIDUAL INSTRUCTIONS ARE PROVIDED WITH THE RESPECTIVE PRODUCT.

STEP 4

MOUNT HANGER ASSEMBLY ON DOOR AND SECURE TOP WITH #10 X 1-1/2" SCREWS (2), SECURE SIDE WITH 5/16"-18 HEX BOLTS (2), 5/16" PLAIN WASHERS (4), AND 5/16" HEX NUTS (2).

STEP 5

PLACE DOOR AND HANGERS INTO C-104 OR C-108 TRACK AND SECURE TO HEADER. IF ACCESS TO ENDS OF TRACK IS RESTRICTED: PLACE HANGERS IN TRACK BEFORE MOUNTING TRACK, RAISE DOOR INTO POSITION AND INSERT BOLTS.

STEP 6

ADJUST DOOR HEIGHT AND PLUMB WITH 1/4" WRENCH ON BOLT. LOCK ADJUSTMENT BY TIGHTENING HEX NUT AGAINST TOP PLATE WITH 1/2" WRENCH.

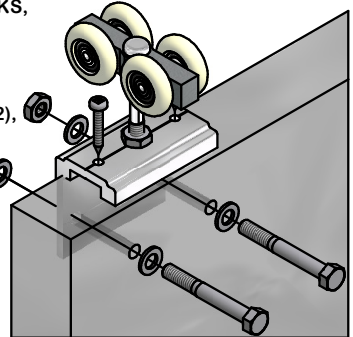
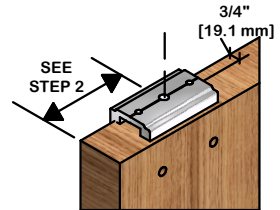

K.N. CROWDER MFG. INC.

1220 BURLOAK DRIVE
BURLINGTON, ONTARIO, CANADA, L7L 6B3
TELEPHONE: 905-315-9788 - FAX: 905-315-8090
TOLL FREE FAX: 1-800-567-0123

K.N. CROWDER INC.

210 EIGHTH STREET SOUTH
LEWISTON, NEW YORK, U.S.A. 14092
TELEPHONE: 1-716-754-8247
TOLL FREE FAX: 1-800-567-0123

WEBSITE: www.kncrowder.com --- E-MAIL: customerservice@kncrowder.com