

SCHLAGE

AL-Series

Service manual

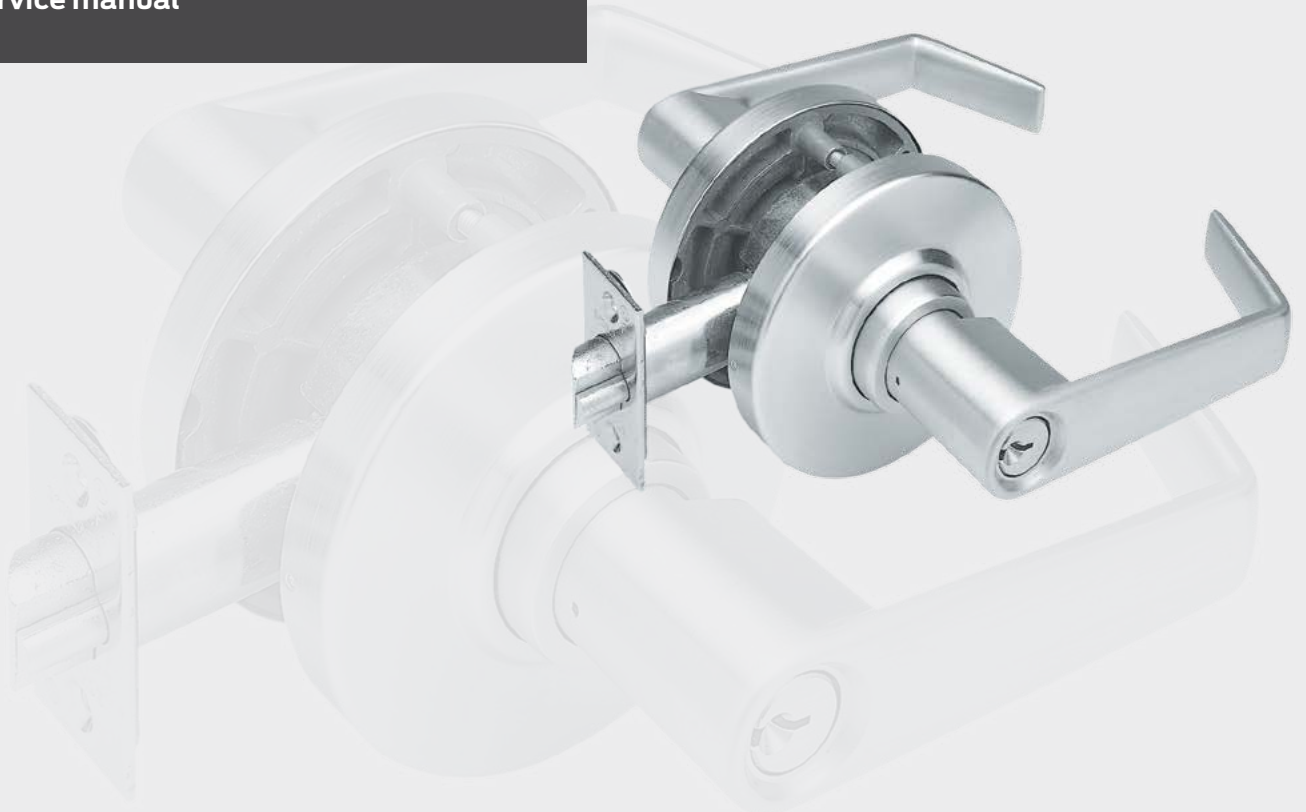

Contents

5 Introduction

4 Trim Assemblies

- 5 Passage Latch Trim
- 6 Exit Lock Trim
- 7 Bath/Bedroom Privacy Lock Trim
- 8 Hospital Privacy Lock Trim
- 9 Entrance/Office Lock Trim
- 10 Entrance Lock Trim
- 11 Classroom Lock Trim
- 12 Storeroom Lock Trim
- 13 Faculty Restroom Lock Trim
- 14 Single Dummy Trim

15 Trim Options

- 15 Levers
- 15 Lever Designs
- 15 Lever Inserts
- 16 Tactile Warning
- 16 Roses
- 16 Trim Finishes

17 Chassis Assemblies

- 18 AL10S Passage Lock Chassis Assembly
- 19 AL25D Exit Lock Chassis Assembly
- 20 AL40S Bath/Bedroom Lock Chassis Assembly
- 21 AL44S Hospital Privacy Lock Chassis Assembly
- 22 AL50PD Entrance/Office Lock Chassis Assembly
- 23 AL53PD Entrance Lock Chassis Assembly
- 24 AL70PD Classroom Lock Chassis Assembly
- 25 AL80PD Storeroom Lock Chassis Assembly
- 26 AL85PD Faculty Restroom Lock Chassis Assembly

27 Latches

- 27 Latch accessories and adapters

28 Strikes

29 Cylinder Options

- 29 Standard Cylinders
- 29 FSIC and SFIC Cylinders
- 30 Full Size Interchangeable Core
- 30 Small Format Interchangeable Core
- 31 Interchangeable Core Related Parts and Levers
- 31 Cylinder Conversion

32 Parts

- 32 Parts for 2-Inch Doors
- 32 Hub, Frame and Housing Kits
- 32 Plunger Units

33 Screws and Screw Packs

- 33 Screws
- 33 Screw Packs, Standard
- 33 Screw Packs, Torx

34 Door Handing

35 Ordering Procedure

35 Limited Warranty

Introduction

This manual contains a complete listing of AL-Series (Grade 2) cylindrical lock parts and assemblies manufactured by the Schlage Lock Company. This edition lists components of AL-Series locks manufactured after June, 2003.

Exploded views of chassis and trim are shown with parts for standard size doors, with accompanying charts to identify parts for replacement purposes. In addition, lock trim ordering procedures, general cylinder information, and all auxiliary components of the AL-Series cylindrical locks are included.

Schlage AL-Series lock parts are manufactured to close tolerances and are interchangeable between functions. Conversion of functions may be performed by identifying necessary substitution parts and following assembly as indicated on the lock drawings.

Standard Features*	
Certifications	ANSI/BHMA Certified A156.2, 2003, Series 4000, Grade 2, UL listed for 3-hour fire door
Latch	1 $\frac{1}{8}$ " x 2 $\frac{1}{4}$ ", Square corner faceplate, 1" housing diameter, $\frac{1}{2}$ " throw
Strike	1 $\frac{1}{4}$ " x 4 $\frac{7}{8}$ ", ANSI, Square corner, no box
Backset	2 $\frac{3}{4}$ "
Cylinder	6-Pin solid brass, keyed 6-pin, S123 keyway, keyed different (KD)**
Door Range	1 $\frac{3}{8}$ " – 1 $\frac{7}{8}$ "
Keys	Two nickel silver cut keys per lock, 6-pin, S123 section**

* Locks are furnished with standard features unless otherwise specified.

** Items specified in C keyway will be furnished with cylinder keyed 5-pin and with 5-pin keys unless otherwise specified.

Lock Assembly Drawing Index

The Lock Assembly Drawing Index provides illustrations and textual descriptions of available functions. Page numbers for full trim and chassis drawings are referenced.

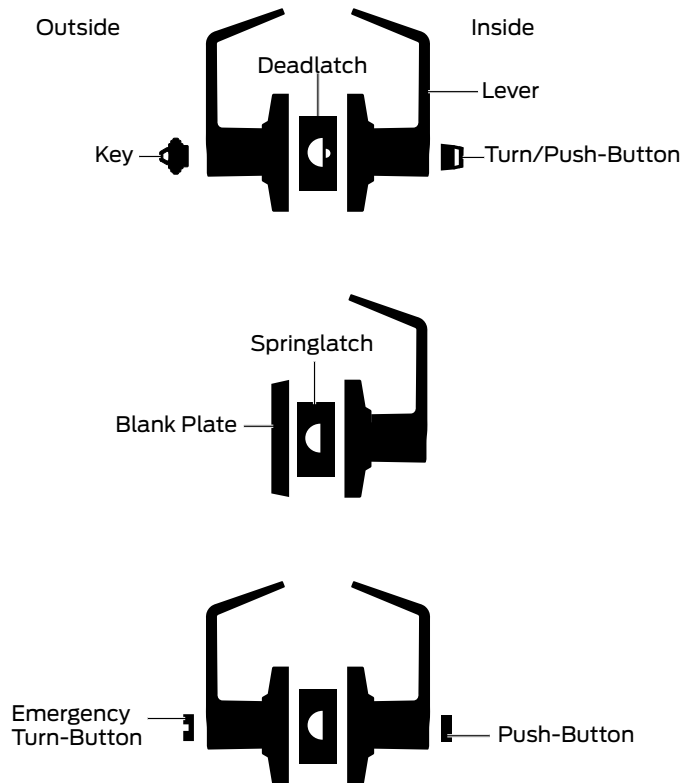

Function		ANSI A156.2, 2003, Series 4000, Grade 2			Trim	Chassis
Schlage	ANSI	Description	Outside function	Inside function	Page	Page
AL10S	F75	Passage Latch	Lever is always unlocked.	Lever is always unlocked and is always free for immediate egress.	9	22
AL25D		Exit Lock	Blank plate outside.	Lever is always unlocked and is always free for immediate egress.	10	23
AL40S	F76	Bath/Bedroom Privacy Lock	Outside lever is locked by inside push-button. May be unlocked from outside with small screwdriver (not included), or with 35-250 emergency key..	Push-button locks outside lever. Turning inside lever or closing door releases button. Inside lever is always free for immediate egress.	11	24

Note: Any function with a deadlatch locks the latchbolt when door is closed. See page 5 for identification.

* AL85 functions are not available in Full Size or Small Format Interchangeable cores.

Lock Assembly Drawing Index

Function		ANSI A156.2, 2003, Series 4000, Grade 2			Trim	Chassis
Schlage	ANSI	Description	Outside function	Inside function	Page	Page
AL44S		Hospital Privacy Lock	Outside lever is locked by inside push-button. Unlocked from outside by turning emergency turn-button.	Push-button locks outside lever. Turning inside lever or closing door releases button. Inside lever is always free for immediate egress.	12	25
AL50PD	F82	Entrance/ Office Lock	Outside lever is locked by inside push-button. Unlocked from outside with key.	Push-button locks outside lever. Turning inside lever releases button. Inside lever is always free for immediate egress.	13	26
AL53PD	F109	Entrance Lock	Turn/Push-Button: Outside lever is locked by pushing and turning the inside turn/push-button. Key must be used until turn/push-button is unlocked. Push-Button: Outside lever is locked by pushing the inside push-button. Key must be used until push-button is unlocked. Unlocked from outside with key.	Turn/Push-Button: Outside lever is locked by pushing and turning the inside turn/push-button until button is manually unlocked. Push-Button: Pushing button locks outside lever. Turning inside lever releases button. Inside lever is always free for immediate egress.	14	27
AL70PD	F84	Classroom Lock	Outside lever is locked and unlocked by key outside.	Inside lever is always unlocked and free for immediate egress.	15	28
AL80PD	F86	Storeroom Lock	Outside lever is fixed. Entrance by key only.	Inside lever is always unlocked and free for immediate egress.	16	29
AL85PD *	F93	Faculty Restroom Lock with Indicator Cylinder	Outside lever is fixed. Entrance by key only. When push-button is activated from inside, only the emergency master key will allow entrance.	Push-button activates occupancy indicator, allowing only emergency master key to operate. Turning lever or closing door releases button. Spanner-button rotation provides lock-out feature. Inside lever is always free for immediate egress.	17	30
AL170		Single Dummy Trim	Dummy trim for one side of door. Use as door pull or as matching inactive trim.		18	—

Note: Any function with a deadlatch locks the latchbolt when door is closed. See page 5 for identification.

* AL85 functions are not available in Full Size or Small Format Interchangeable cores.

Trim Assemblies

- 5 Passage Latch Trim
- 6 Exit Lock Trim
- 7 Bath/Bedroom Privacy Lock Trim
- 8 Hospital Privacy Lock Trim
- 9 Entrance/Office Lock Trim
- 10 Entrance Lock Trim
- 11 Classroom Lock Trim
- 12 Storeroom Lock Trim
- 13 Faculty Restroom Lock Trim
- 14 Single Dummy Trim

Passage Latch Trim

AL10S

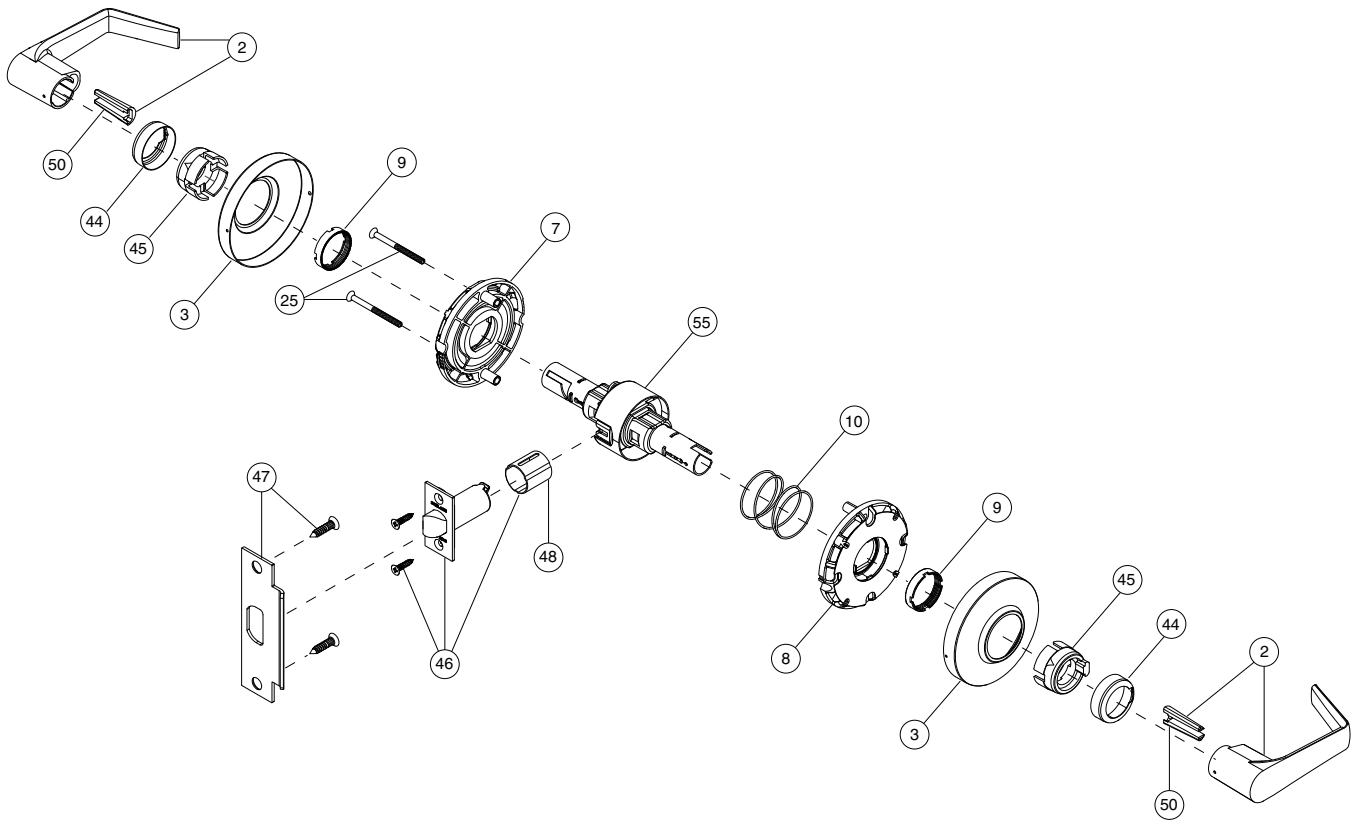

No.	Description	Part no.
2	Closed Lever (2)	51-025*
3	Rose (2)	04-060
7	Inside Spring Cage	A100-053**
8	Outside Spring Cage	A100-054**
9	Castle Nut (2)	C604-354
10	Anchor Spring	C503-308
25	Spring Cage Mounting Screw (2)	C604-395

No.	Description	Part no.
44	Driver Cap	A700-041**
45	Driver Bushing	A700-039**
46	Springlatch	11-116
47	Strike, ANSI standard, no box	10-025
48	Latch Housing Sleeve (for 7/8" housing only)	G506-815
50	Lever insert (2)	A700-044**
55	AL10 Chassis	61-210-134***

* For locks manufactured after June 2003. See **Levers** on page 19 for a complete list of lever part numbers.

** For locks manufactured after May 2002.

*** Chassis part number is for reference only.

Trim Assemblies

Exit Lock Trim

AL25D

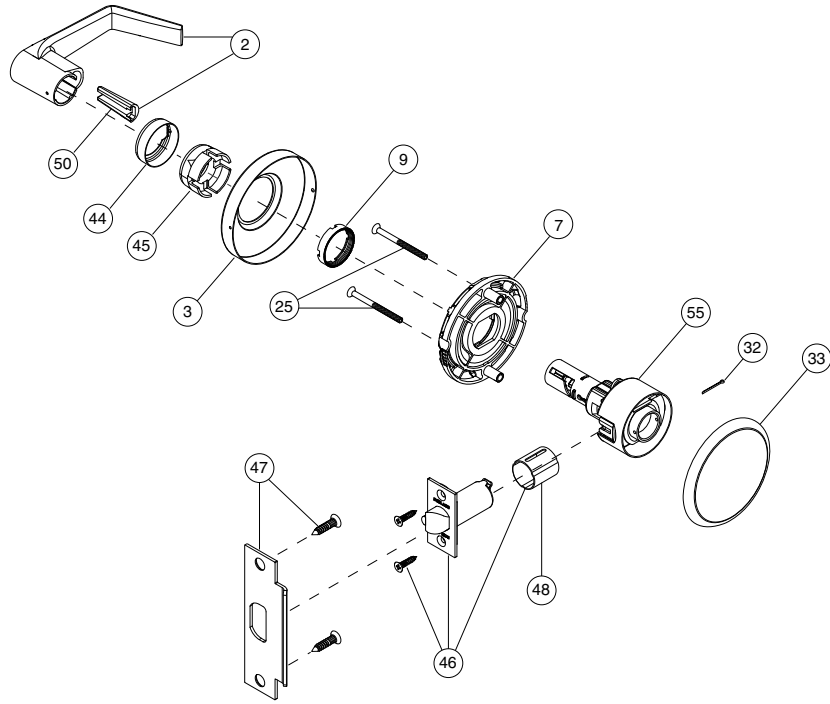

No.	Description	Part no.
2	Closed Lever	51-025*
3	Rose	04-060
7	Inside Spring Cage	A100-053**
9	Castle Nut	C604-354
25	Spring Cage Mounting Screws (2)	C604-395
32	Cotter Pin	C604-273
33	Rose, Outside Blank	C604-402

No.	Description	Part no.
44	Driver Cap	A700-041**
45	Driver Bushing	A700-039**
46	Deadlatch	11-096
47	Strike, ANSI standard, no box	10-025
48	Latch Housing Sleeve (7/8" housing only)	G506-815
50	Lever insert	A700-044*
55	AL25 Chassis	61-225-134***

* For locks manufactured after June 2003. See Levers on page 19 for a complete list of lever part numbers.

** For locks manufactured after May 2002.

*** Chassis part number is for reference only.

AL25 Door Thickness Adjustment

Door Thickness	Blank Rose Adjustment
1 3/8"	Place cotter pin at hole A on the Blank Rose.
1 3/4"	Place cotter pin at hole B on the Blank Rose.
2"	Non-standard door thickness for AL25. Specify 2" door thickness on order. If cotter pin adjustment is necessary, place at hole B.

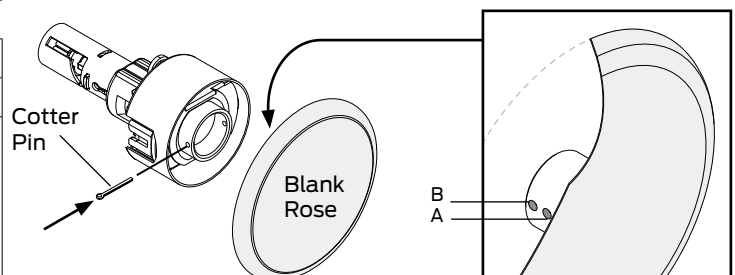

Bath/Bedroom Privacy Lock Trim

AL40S

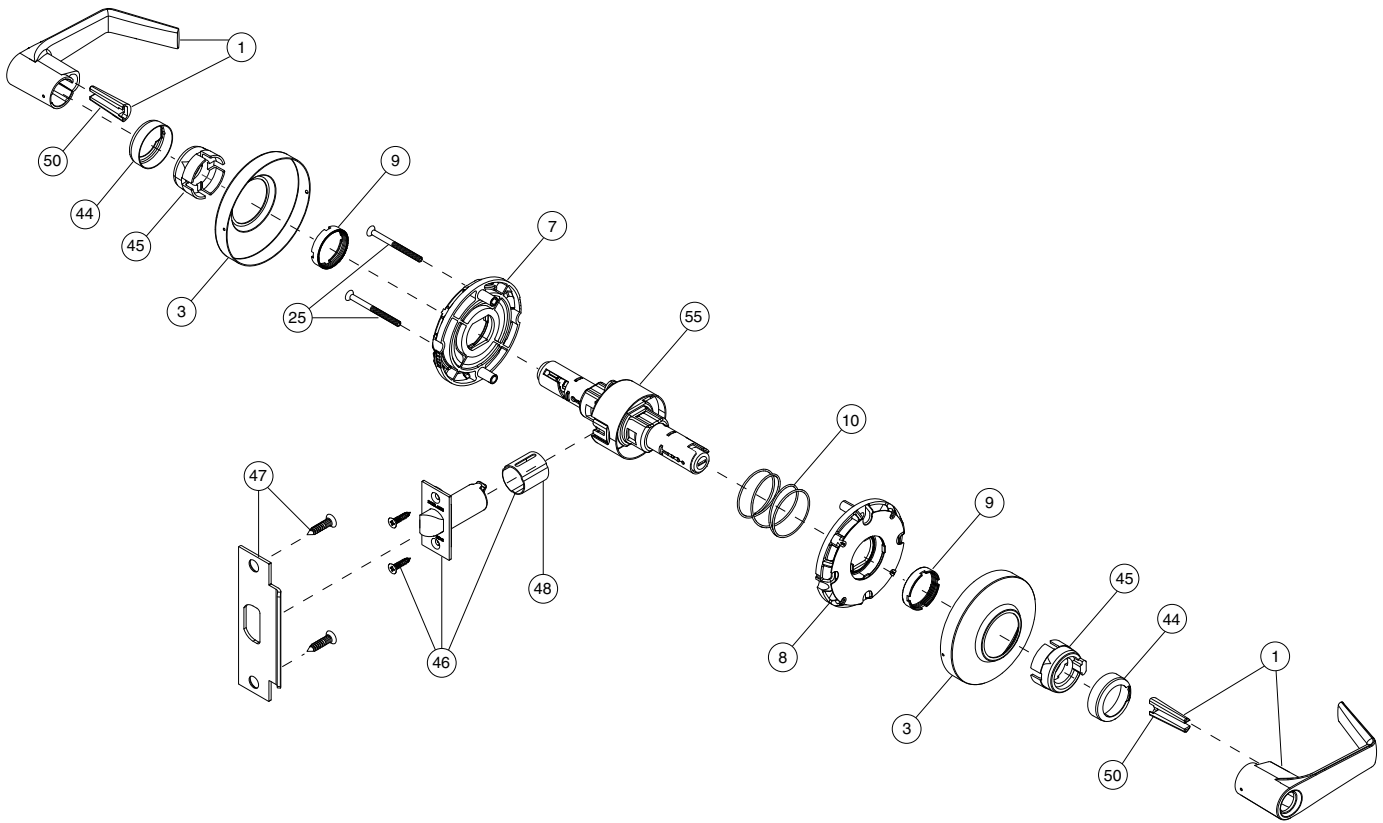

No.	Description	Part no.
1	Open Lever (2)	51-026*
3	Rose (2)	04-060
7	Inside Spring Cage	A100-053**
8	Outside Spring Cage	A100-054**
9	Castle Nut (2)	C604-354
10	Anchor Spring	C503-308
25	Spring Cage Mounting Screws (2)	C604-395

No.	Description	Part no.
44	Driver Cap	A700-041**
45	Driver Bushing	A700-039**
46	Springlatch	11-116
47	Strike, ANSI standard, no box	10-025
48	Latch Housing Sleeve (for 7/8" housing only)	G506-815
50	Lever insert (2)	A700-044**
55	AL40 Chassis	61-240-134***

* For locks manufactured after June 2003. See Levers on page 19 for a complete list of lever part numbers.

** For locks manufactured after May 2002.

*** Chassis part number is for reference only.

Hospital Privacy Lock Trim

AL44S

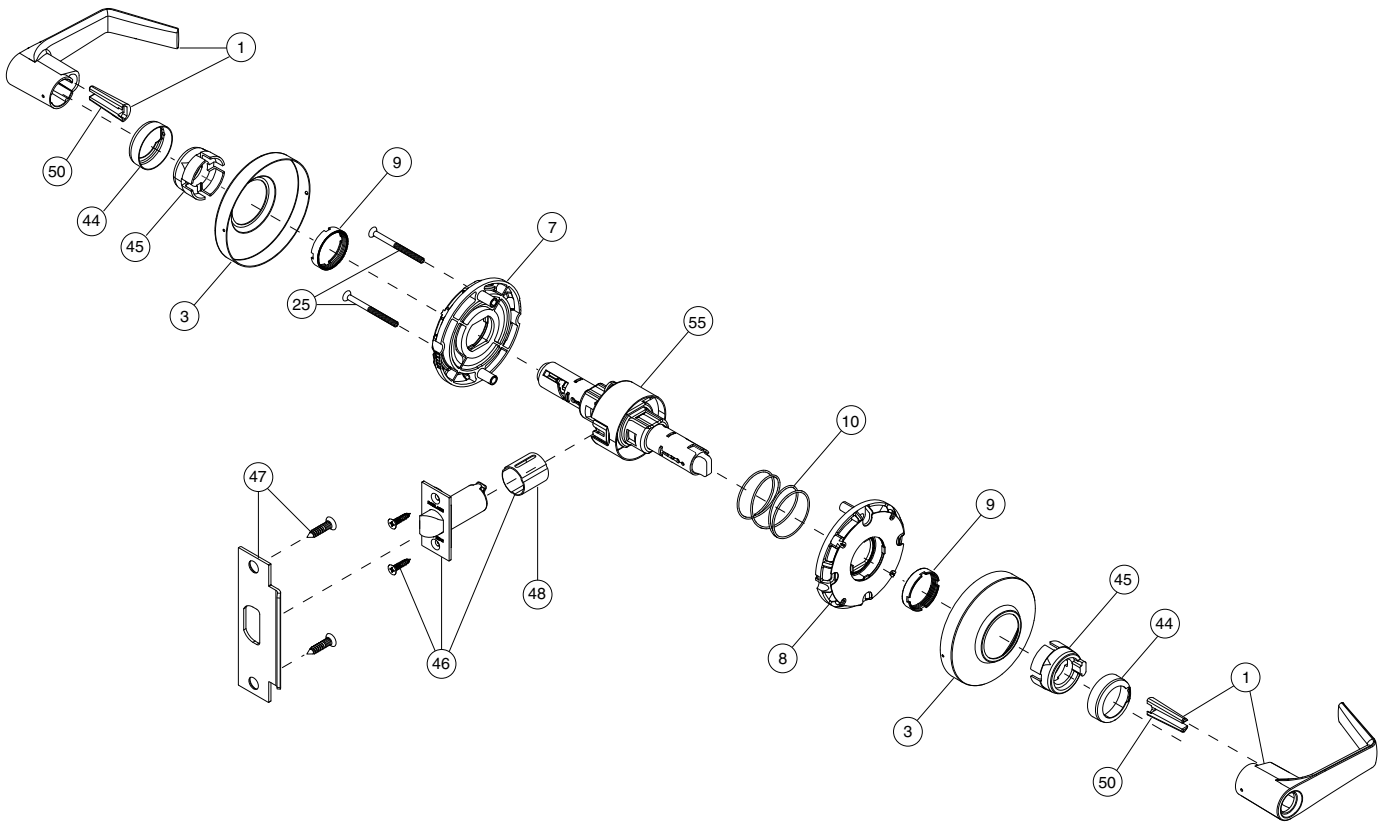

No.	Description	Part no.
1	Open Lever (2)	51-026*
3	Rose (2)	04-060
7	Inside Spring Cage	A100-053**
8	Outside Spring Cage	A100-054**
9	Castle Nut (2)	C604-354
10	Anchor Spring	C503-308
25	Spring Cage Mounting Screws (2)	C604-395

No.	Description	Part no.
44	Driver Cap	A700-041**
45	Driver Bushing	A700-039**
46	Springlatch	11-116
47	Strike, ANSI standard, no box	10-025
48	Latch Housing Sleeve (for 7/8" housing only)	G506-815
50	Lever insert (2)	A700-044*
55	AL44 Chassis	61-240-134***

* For locks manufactured after June 2003. See **Levers** on page 19 for a complete list of lever part numbers.

** For locks manufactured after May 2002.

*** Chassis part number is for reference only.

Trim Assemblies

Entrance/Office Lock Trim

AL50PD

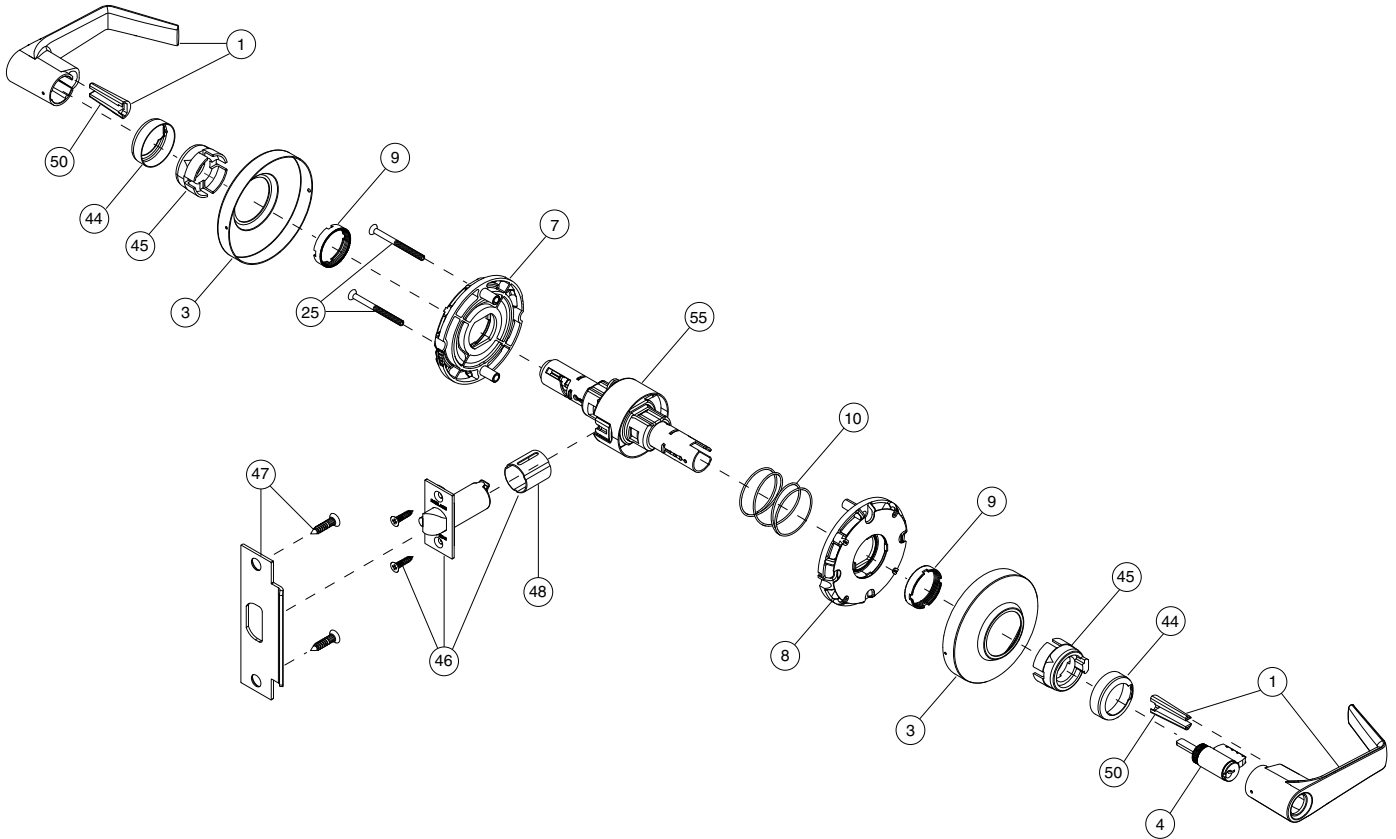

No.	Description	Part no.
1	Open Lever (2)	51-026*
3	Rose (2)	04-060
4	Cylinder	21-020
7	Inside Spring Cage	A100-053**
8	Outside Spring Cage	A100-054**
9	Castle Nut (2)	C604-354
10	Anchor Spring	C503-308
25	Spring Cage Mounting Screws (2)	C604-395

No.	Description	Part no.
44	Driver Cap	A700-041**
45	Driver Bushing	A700-039**
46	Deadlatch	11-096
47	Strike, ANSI standard, no box	10-025
48	Latch Housing Sleeve (for 7/8" housing only)	G506-815
50	Insert (2)	A700-044**
55	AL50 Chassis	61-253-134***

* For locks manufactured after June 2003. See Levers on page 19 for a complete list of lever part numbers.

** For locks manufactured after May 2002.

*** Chassis part number is for reference only.

Trim Assemblies

Entrance Lock Trim

AL53PD

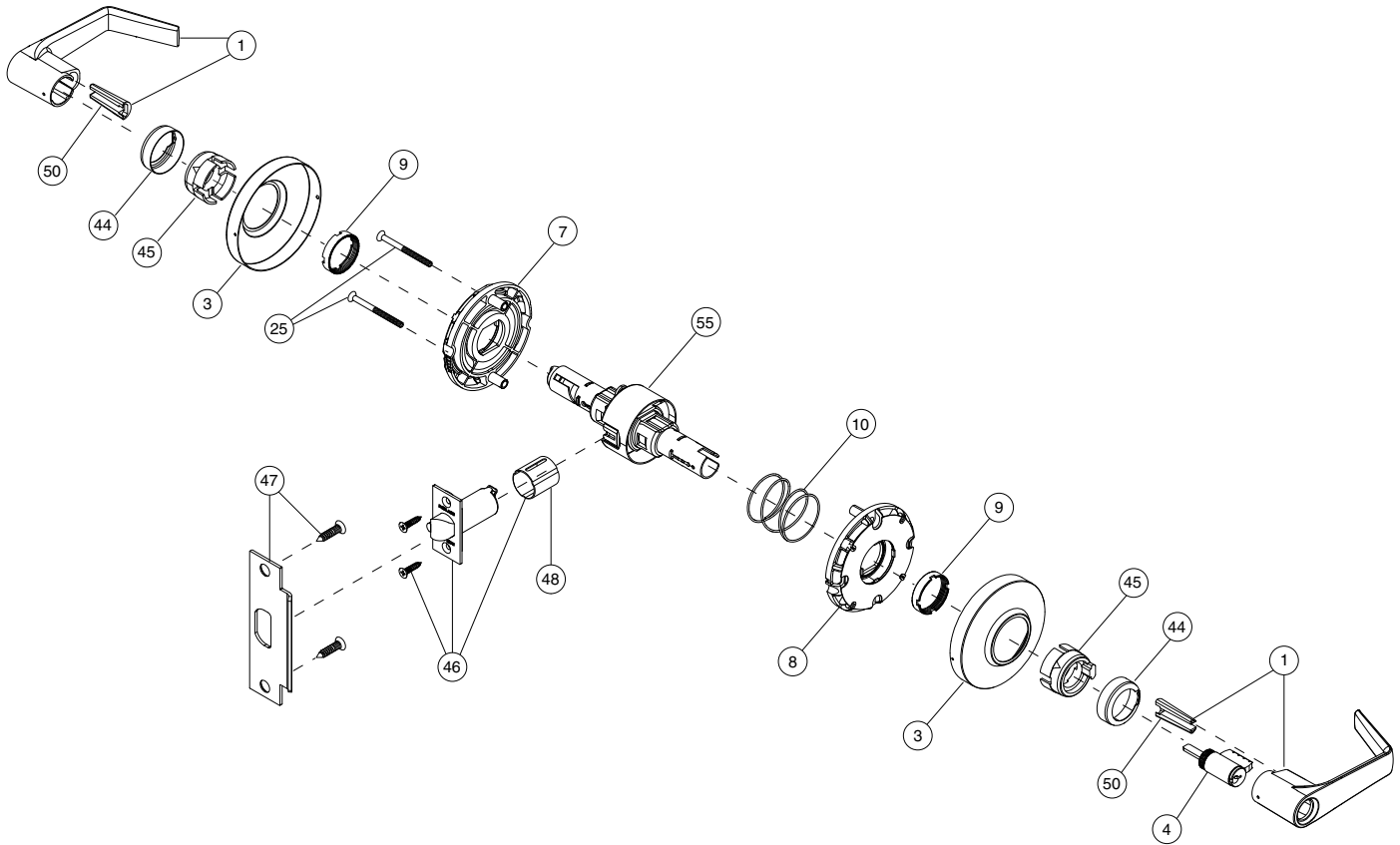

No.	Description	Part no.
1	Open Lever (2)	51-026*
3	Rose (2)	04-060
4	Cylinder	21-020
7	Inside Spring Cage	A100-053**
8	Outside Spring Cage	A100-054**
9	Castle Nut (2)	C604-354
10	Anchor Spring	C503-308
25	Spring Cage Mounting Screws (2)	C604-395

No.	Description	Part no.
44	Driver Cap	A700-041**
45	Driver Bushing	A700-039**
46	Deadlatch	11-096
47	Strike, ANSI standard, no box	10-025
48	Latch Housing Sleeve (for 7/8" housing only)	G506-815
50	Insert (2)	A700-044**
55	AL53 Chassis	61-253-134***

* For locks manufactured after June 2003. See Levers on page 19 for a complete list of lever part numbers.

** For locks manufactured after May 2002.

*** Chassis part number is for reference only.

Classroom Lock Trim

AL70PD

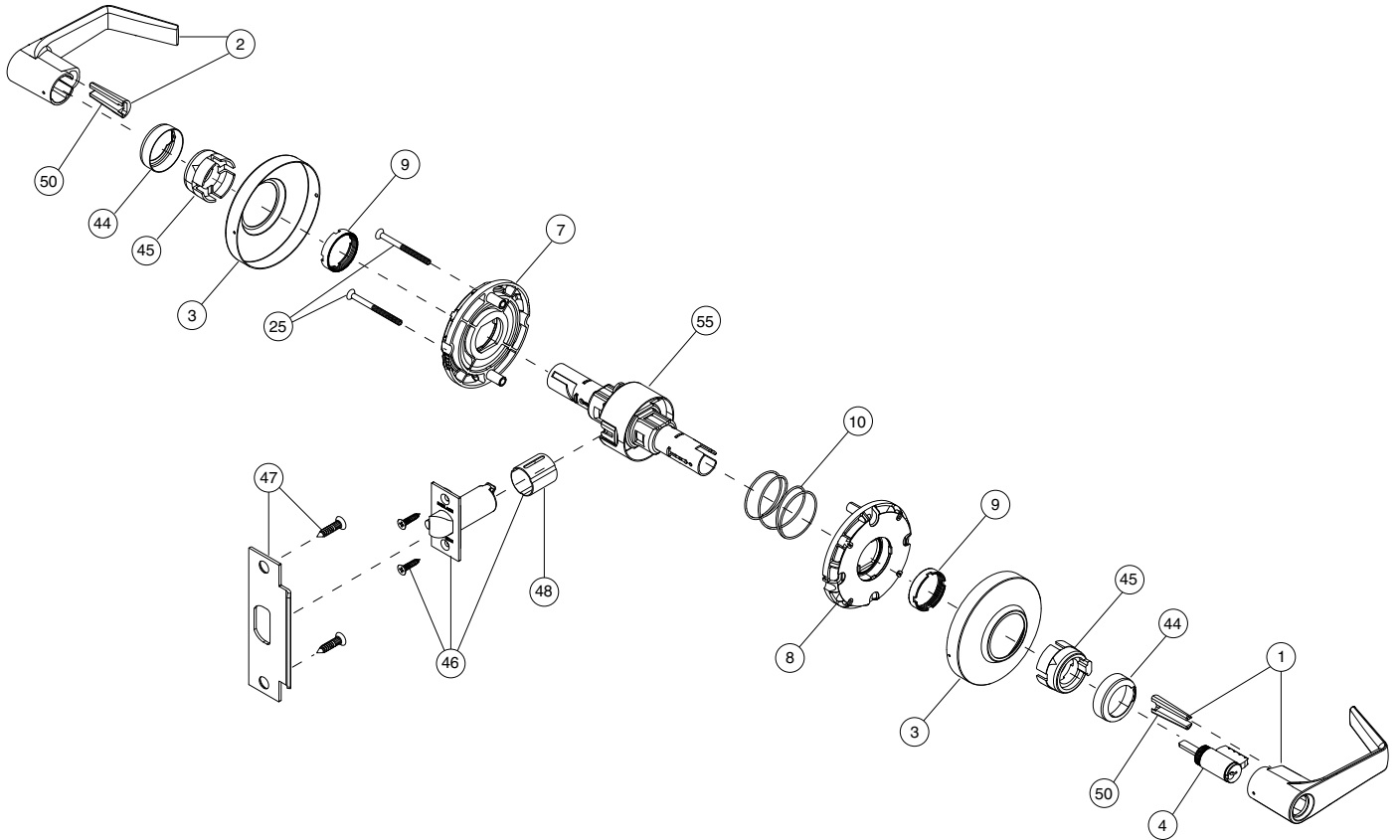

No.	Description	Part no.
1	Open Lever	51-026*
2	Closed Lever	51-025*
3	Rose (2)	04-060
4	Cylinder	21-020
7	Inside Spring Cage	A100-053**
8	Outside Spring Cage	A100-054**
9	Castle Nut (2)	C604-354
10	Anchor Spring	C503-308

No.	Description	Part no.
25	Spring Cage Mounting Screws (2)	C604-395
44	Driver Cap	A700-041**
45	Driver Bushing	A700-039**
46	Deadlatch	11-096
47	Strike, ANSI standard, no box	10-025
48	Latch Housing Sleeve (for 7/8" housing only)	G506-815
50	Lever insert (2)	A700-044**
55	AL70 Chassis	61-270-134***

* For locks manufactured after June 2003. See Levers on page 19 for a complete list of lever part numbers.

** For locks manufactured after May 2002.

*** Chassis part number is for reference only.

Storeroom Lock Trim

AL80PD

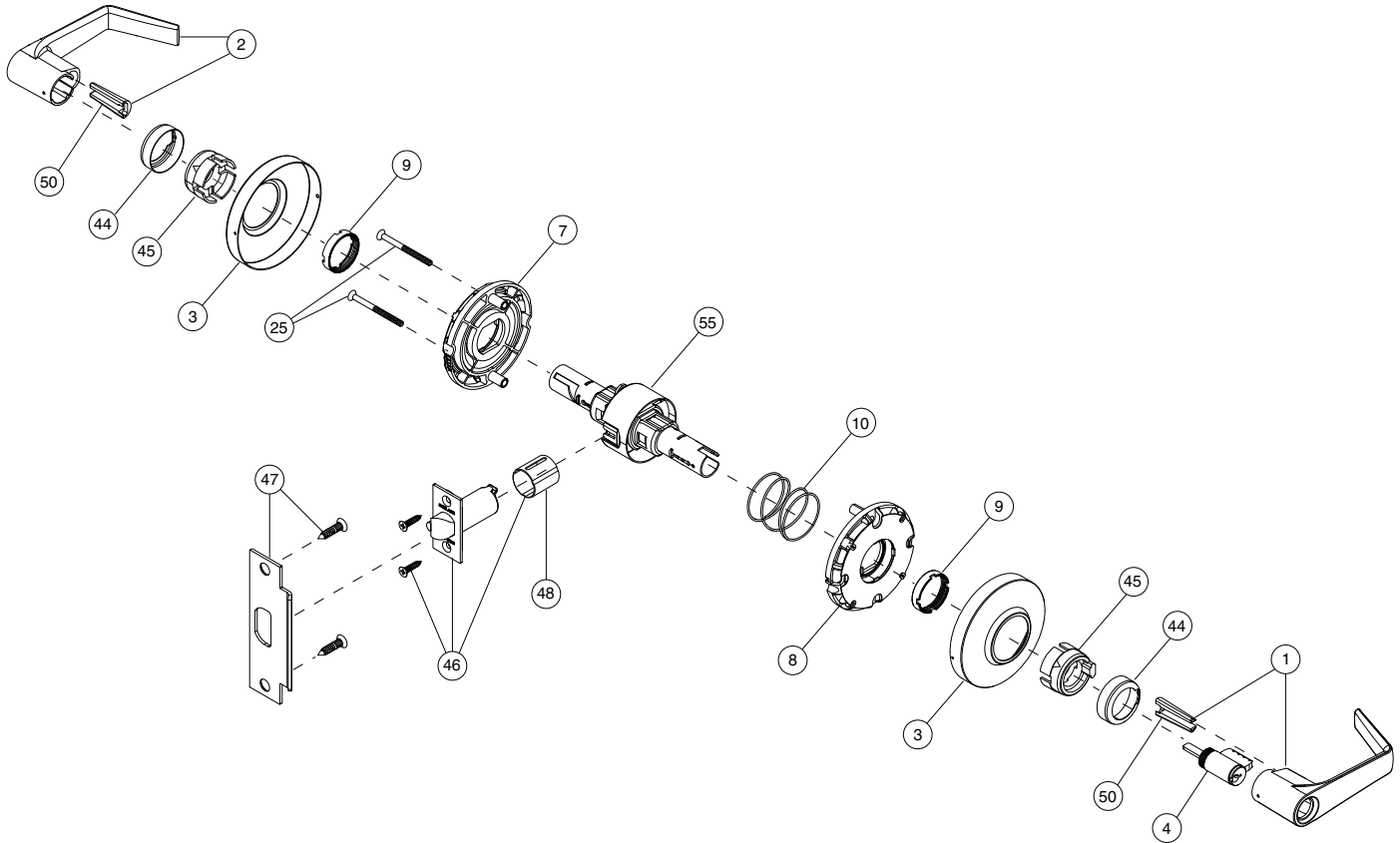

No.	Description	Part no.
1	Open Lever	51-026*
2	Closed Lever	51-025*
3	Rose (2)	04-060
4	Cylinder	21-020
7	Inside Spring Cage	A100-053**
8	Outside Spring Cage	A100-054**
9	Castle Nut (2)	C604-354
10	Anchor Spring	C503-308

No.	Description	Part no.
25	Spring Cage Mounting Screws (2)	C604-395
44	Driver Cap	A700-041**
45	Driver Bushing	A700-039**
46	Deadlatch	11-096
47	Strike, ANSI standard, no box	10-025
48	Latch Housing Sleeve (for 7/8" housing only)	G506-815
50	Lever insert (2)	A700-044**
55	AL80 Chassis	61-280-134***

* For locks manufactured after June 2003. See Levers on page 19 for a complete list of lever part numbers.

** For locks manufactured after May 2002.

*** Chassis part number is for reference only.

Faculty Restroom Lock Trim

AL85PD

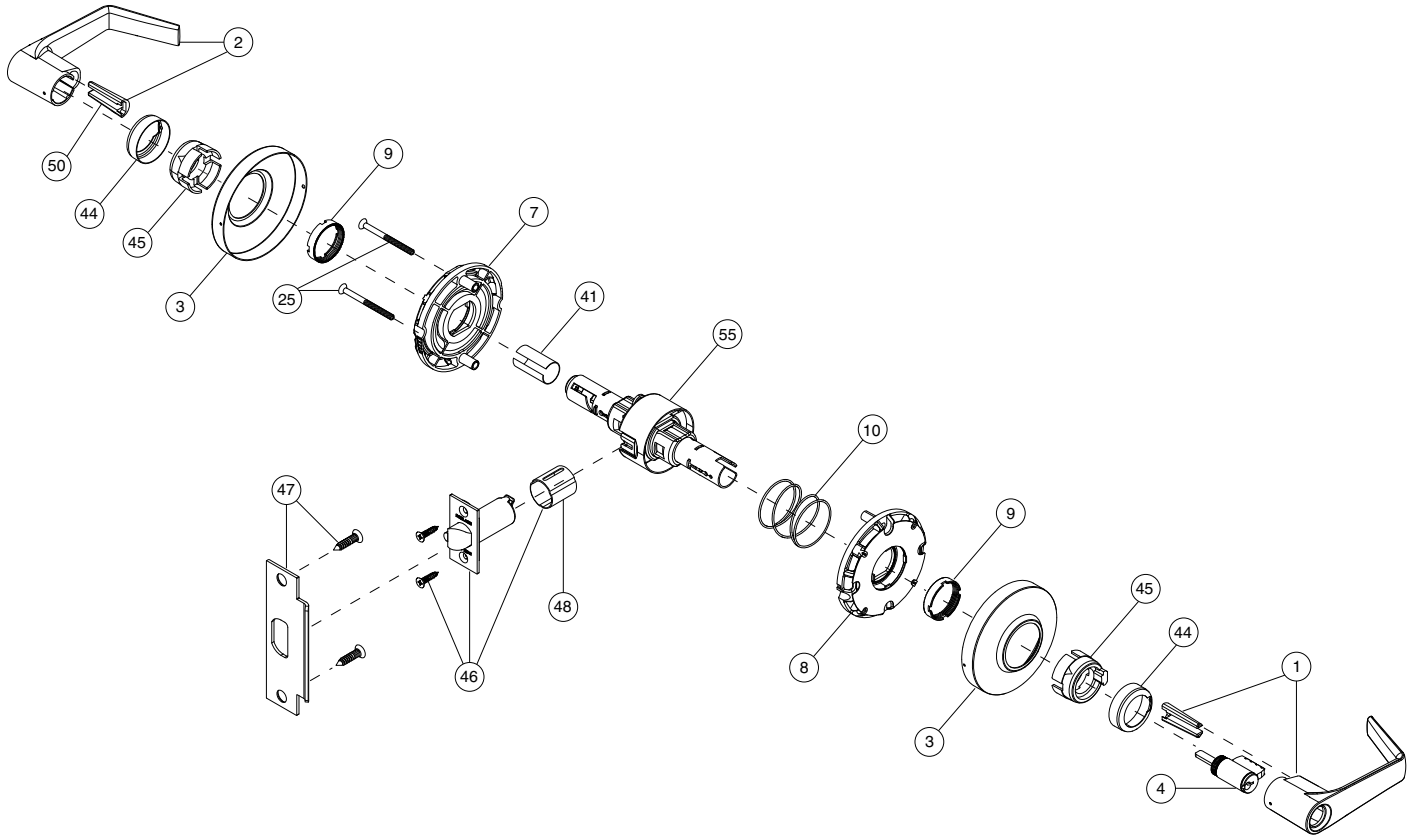

No.	Description	Part no.
1	Open Lever	51-026*
2	Closed Lever	51-025*
3	Rose (2)	04-060
4	Cylinder	21-021
7	Inside Spring Cage	A100-053**
8	Outside Spring Cage	A100-054**
9	Castle Nut (2)	C604-354
10	Anchor Spring	C503-308
25	Spring Cage Mounting Screws (2)	C604-395

No.	Description	Part no.
41	Sleeve, Spindle	A700-003
44	Driver Cap	A700-041**
45	Driver Bushing	A700-039**
46	Deadlatch	11-096
47	Strike, ANSI standard, no box	10-025
48	Latch Housing Sleeve (for 7/8" housing only)	G506-815
50	Lever insert (2)	A700-044**
55	AL85 Chassis	61-285-134***

* For locks manufactured after June 2003. See Levers on page 19 for a complete list of lever part numbers.

** For locks manufactured after May 2002.

*** Chassis part number is for reference only.

Single Dummy Trim

AL170

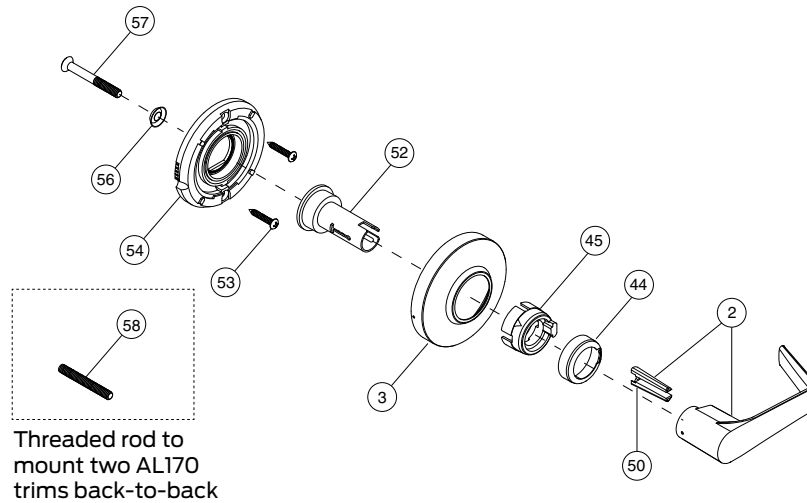

No.	Description	Part no.
2	Closed Lever	51-025*
3	Rose	04-060
7	Inside Spring Cage	A100-053**
44	Driver Cap	A700-041**
45	Driver Bushing	A700-039**
50	Lever insert	A700-044**

No.	Description	Part no.
52	Spindle and Hub	A710-007
53	Mounting Screws (2)	L583-133
54	Housing, Spring Cage	C604-400
56	Washer	A501-171
57	Thru Bolt	A501-746
58	Spindle, Threaded Rod	A501-167

* For locks manufactured after June 2003. See Levers on page 19 for a complete list of lever part numbers.

** For locks manufactured after May 2002.

Trim Options

Trim Options

Levers

Description	Part number	Manufactured date
Closed lever and insert	51-021	Before June 2003
Open lever and insert	51-023	
Closed lever and insert	51-025	After June 2003
Open lever and insert	51-026	
Full size core lever and insert	51-022	–
Small format core lever and insert	51-024	

Lever Designs

Levers are pressure cast zinc. All levers are ADA Accessibility compliant. Neptune, Omega and Saturn lever designs meet California code for 1/2" or less return to the door.

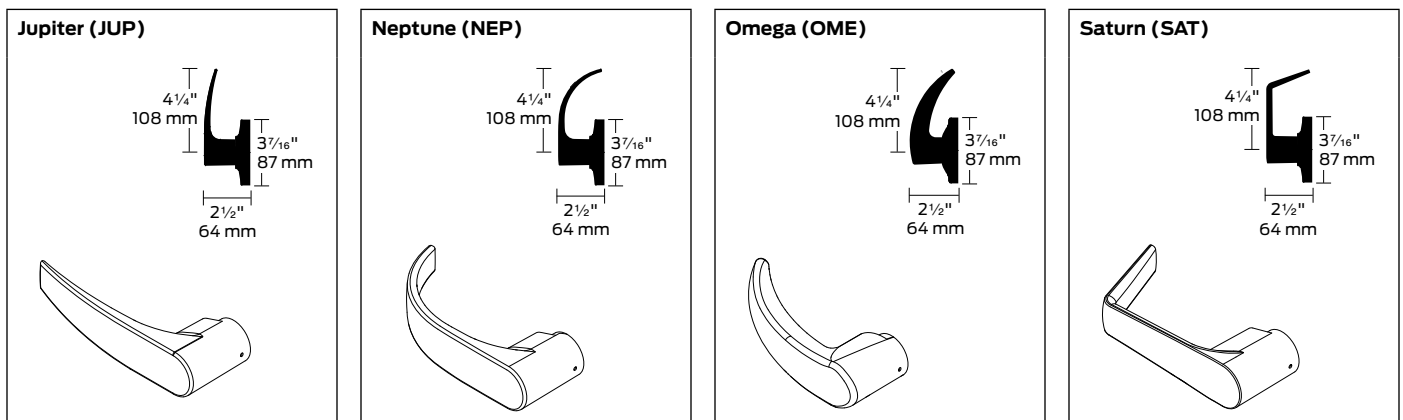

Lever Inserts

Description	Part number
Lever insert for 1 3/8" -1 7/8" doors *	A700-015
Lever insert for 1 3/8" -1 7/8" doors **	A700-044
Lever insert for SFIC	A700-045
Lever insert for interchangeable core with 1 3/8" -1 7/8" doors ***	A700-047

* For locks manufactured before May 2002

** For locks manufactured after May 2002.

*** For locks manufactured after March 2003.

Trim Options

Tactile Warning

Available on Saturn design levers only. Applied to outside lever only unless otherwise specified.

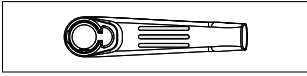

Roses

Rose trims are available in wrought brass or bronze.

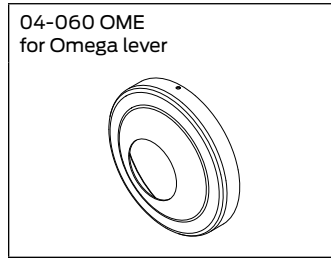
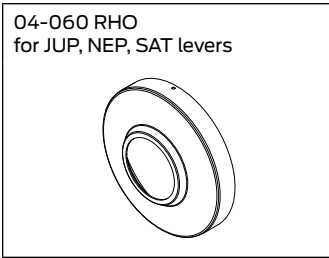

Trim Finishes

Schlage AL-Series lock products are available in a range of durable, top-quality finishes. Most are available with a clear coating that protects against damaging environmental factors, including sea air, high humidity, or corrosive vapors.

The antimicrobial coating on Schlage AL-Series locks works to protect the hardware's surface by inhibiting the growth of bacteria, mold and mildew. The coating is made using ionic silver (AG+), a single atom that is missing one orbital electron that interacts with the bonding sites on the microbe surface. The result is that silver ions surround bacterial cells, blocking food and respiration supply, and slowing bacterial growth.

Finishes are coded according to the Builders Hardware Manufacturers Association (BHMA). The nearest old U.S. equivalent code designations are shown in parentheses.

Code		Description
605	(US 3)	Bright brass
606	(US 4)	Satin brass
609	(US 5)	Antique brass
612	(US 10)	Satin bronze
613	(US 10B)	Oil rubbed bronze

Code		Description
619	(US 15)	Satin nickel
625	(US 25)	Birght chromium plated
626	(US 26D)	Satin chromium plated
626AM		Antimicrobial coating on satin chromium
643e	(US 11)	Aged bronze (e=equivalent to bhma std)

Chassis Assemblies

- 18 Passage Lock Chassis Assembly
- 19 Exit Lock Chassis Assembly
- 20 Bath/Bedroom Lock Chassis Assembly
- 21 Hospital Privacy Lock Chassis Assembly
- 22 Entrance/Office Lock Chassis Assembly
- 23 Entrance Lock Chassis Assembly
- 24 Classroom Lock Chassis Assembly
- 25 Storeroom Lock Chassis Assembly
- 26 Faculty Restroom Lock Chassis Assembly

Passage Lock Chassis Assembly

AL10S

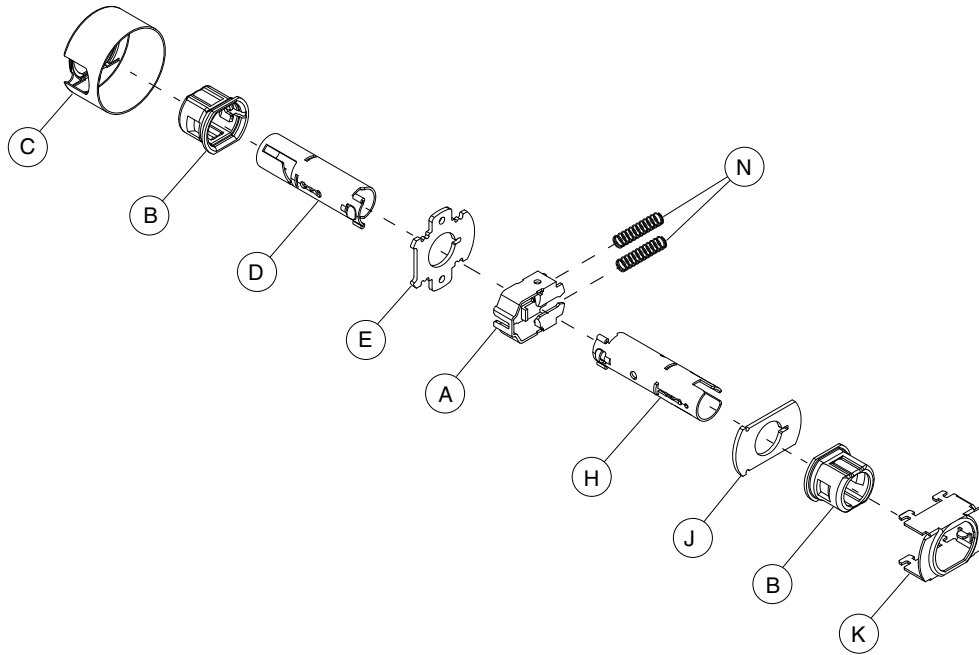

Letter	Description	Part no.
A	Slide, Non-Restoring	A590-181
B	Hub (2)	A700-046
C	Housing, Chassis	A700-057
D	Spindle and Catch, Inside	A710-004
E	Plate, Hub, Inside	A501-305

Letter	Description	Part no.
H	Spindle and Catch, Outside	A710-020
J	Plate, Outside	A700-004
K	Frame, Hub	A700-056
N	Spring, Slide (2)	A501-311

Exit Lock Chassis Assembly

AL25D

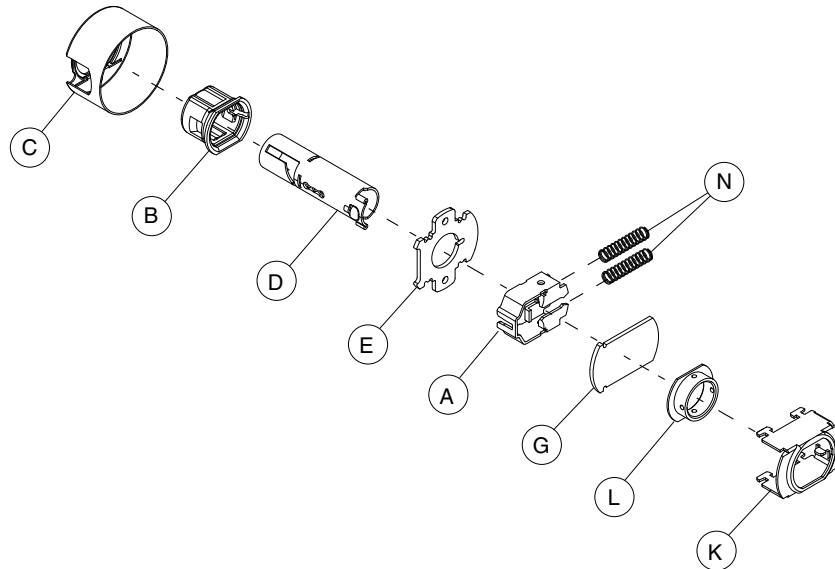

Letter	Description	Part no.
A	Slide, Non-Restoring	A590-181
B	Hub	A700-046
C	Housing, Chassis	A700-057
D	Spindle and Catch, Inside	A710-004
E	Plate, Hub, Inside	A501-305

Letter	Description	Part no.
G	Plate, AL25 Outside	A501-874
K	Frame, Hub	A700-056
L	Hub, AL25 Outside	A700-016
N	Spring, Slide (2)	A501-311

Bath/Bedroom Lock Chassis Assembly

AL40S

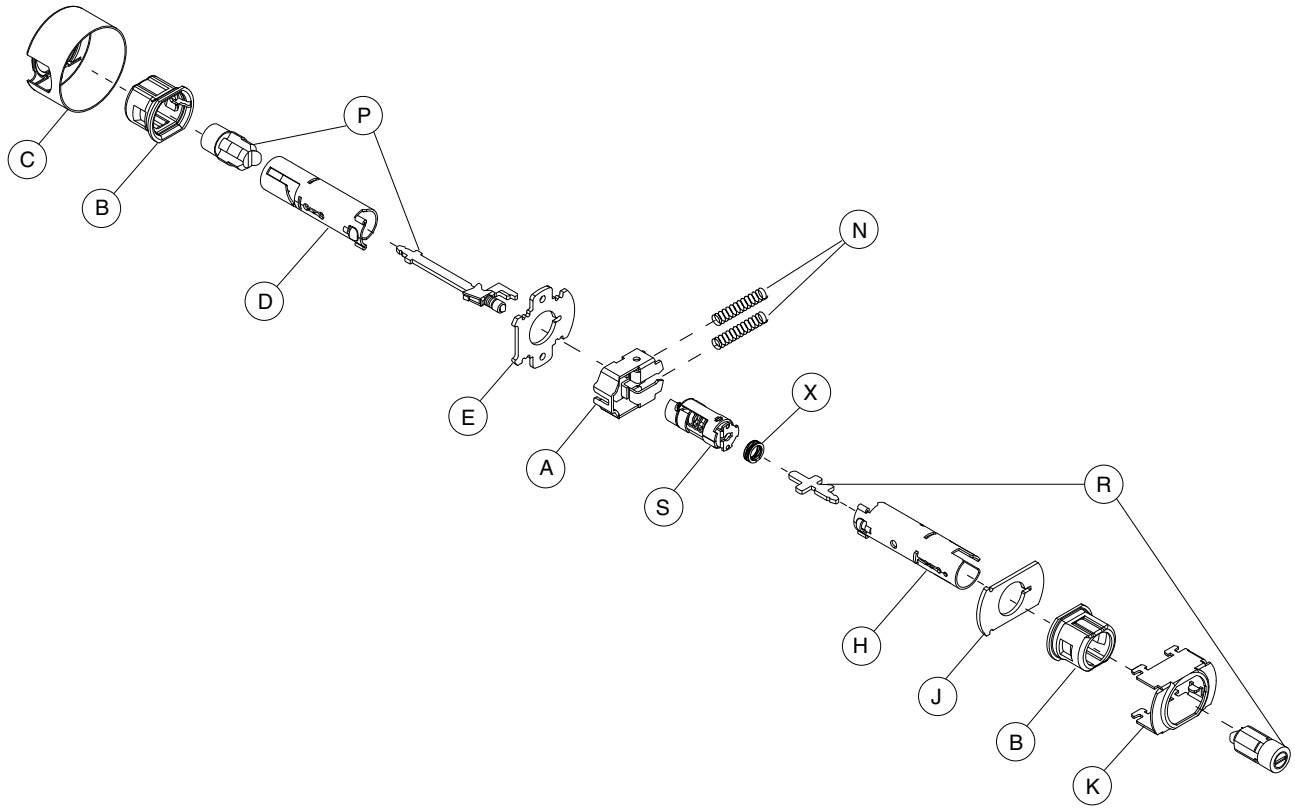

Letter	Description	Part no.
A	Slide, Restoring	A590-180
B	Hub (2)	A700-046
C	Housing, Chassis	A700-057
D	Spindle and Catch, Inside	A710-004
E	Plate, Hub, Inside	A501-305
H	Spindle and Catch, Outside	A710-020
J	Plate, Outside	A700-004

Letter	Description	Part no.
K	Frame, Hub	A700-056
N	Spring, Slide (2)	A501-311
P	Plunger and Button, Inside	51-039
R	Plunger and Button, Outside	51-040
S	Cam and Spring	A301-402
X	Spring	A700-036

Hospital Privacy Lock Chassis Assembly

AL44S

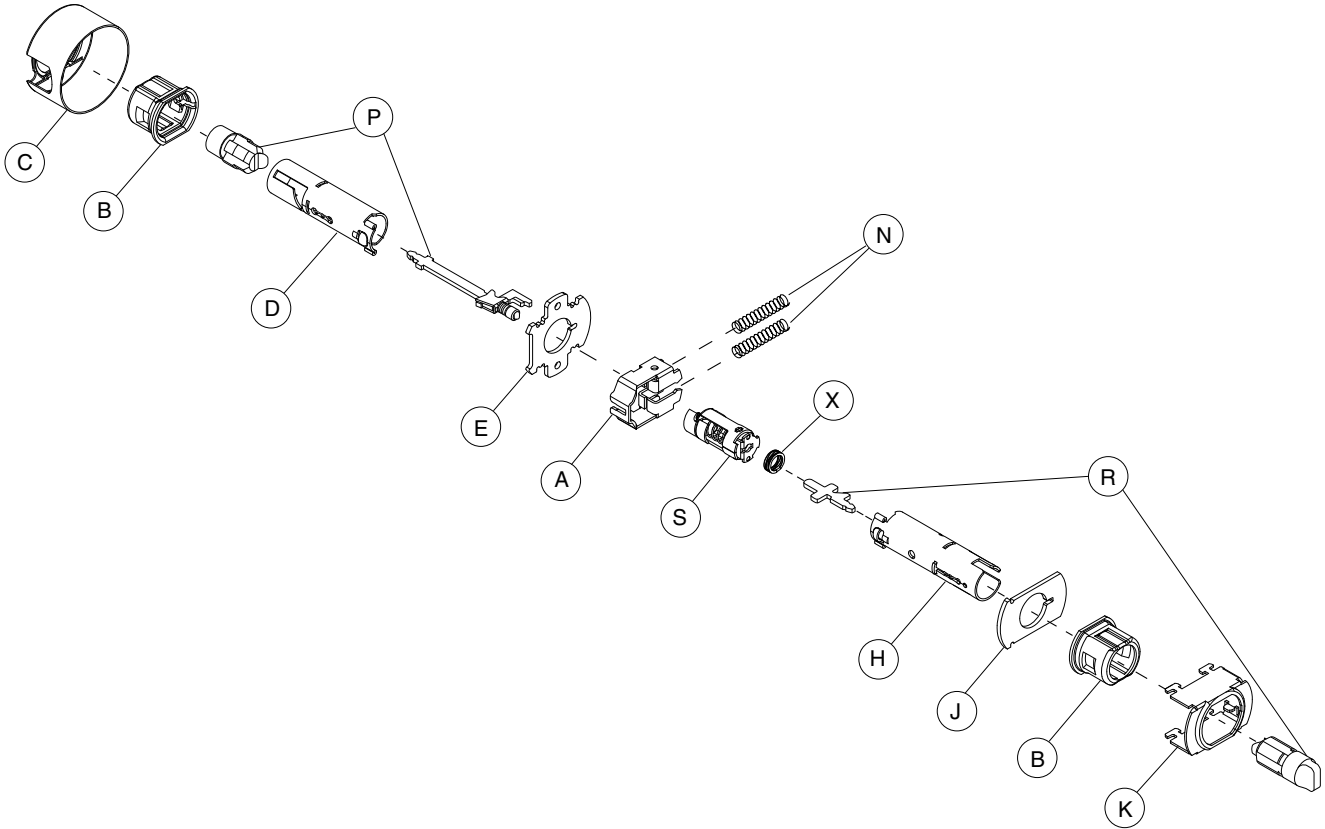

Letter	Description	Part no.
A	Slide, Restoring	A590-180
B	Hub (2)	A700-046
C	Housing, Chassis	A700-057
D	Spindle and Catch, Inside	A710-004
E	Plate, Hub, Inside	A501-305
H	Spindle and Catch, Outside	A710-020
J	Plate, Outside	A700-004

Letter	Description	Part no.
K	Frame, Hub	A700-056
N	Spring, Slide (2)	A501-311
P	Plunger and Button, Inside	51-039
R	Plunger and Button, Outside	51-041
S	Cam and Spring	A301-402
X	Spring	A700-036

Entrance/Office Lock Chassis Assembly

AL50PD

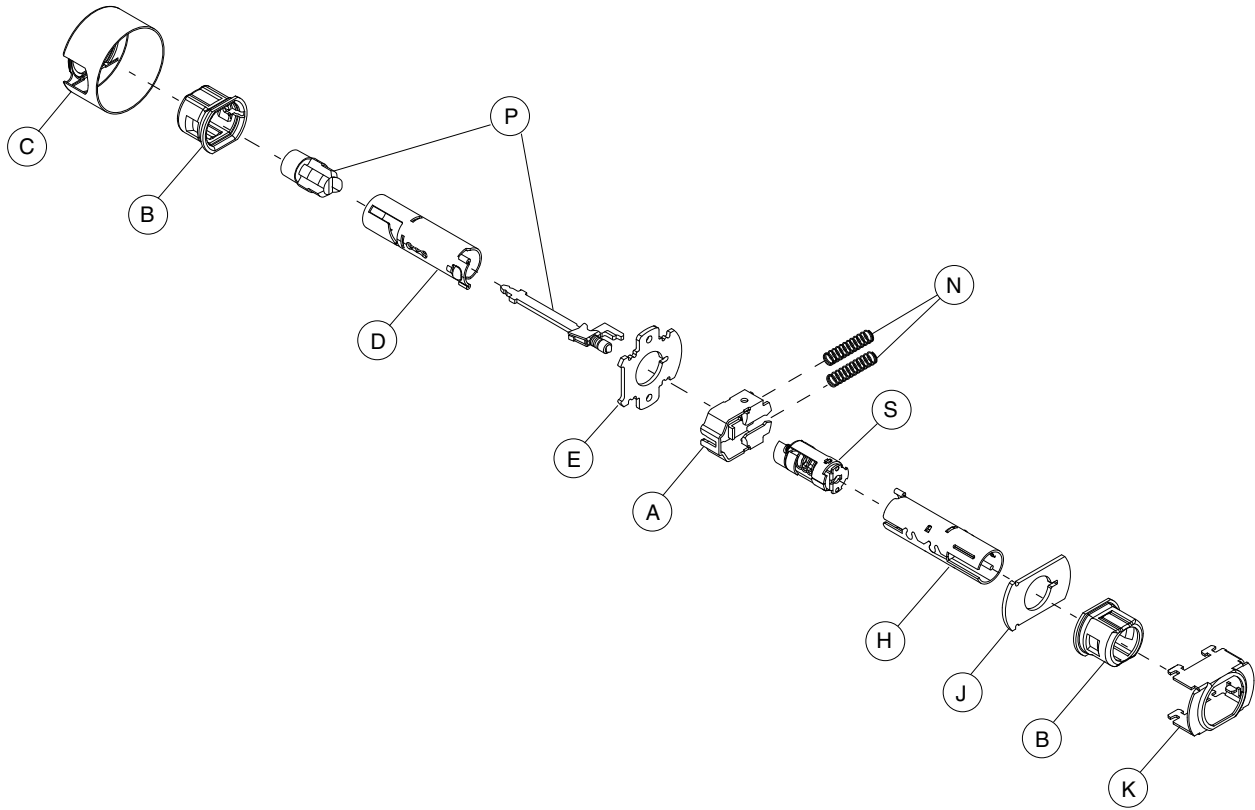

Letter	Description	Part no.
A	Slide, Non-Restoring *	A590-181
B	Hub	A700-046
C	Housing, Chassis	A700-057
D	Spindle and Catch, Inside	A710-004
E	Plate, Hub, Inside	A501-305
H	Spindle and Catch, Outside	A710-001

Letter	Description	Part no.
J	Plate, Outside	A700-004
K	Frame, Hub	A700-056
N	Spring, Slide (2)	A501-311
P	Plunger and Button	51-039
S	Cam and Spring	A301-402

* AL50PD is available with restoring slide. Order by AL50PD x XA11-297.

Entrance Lock Chassis Assembly

AL53PD

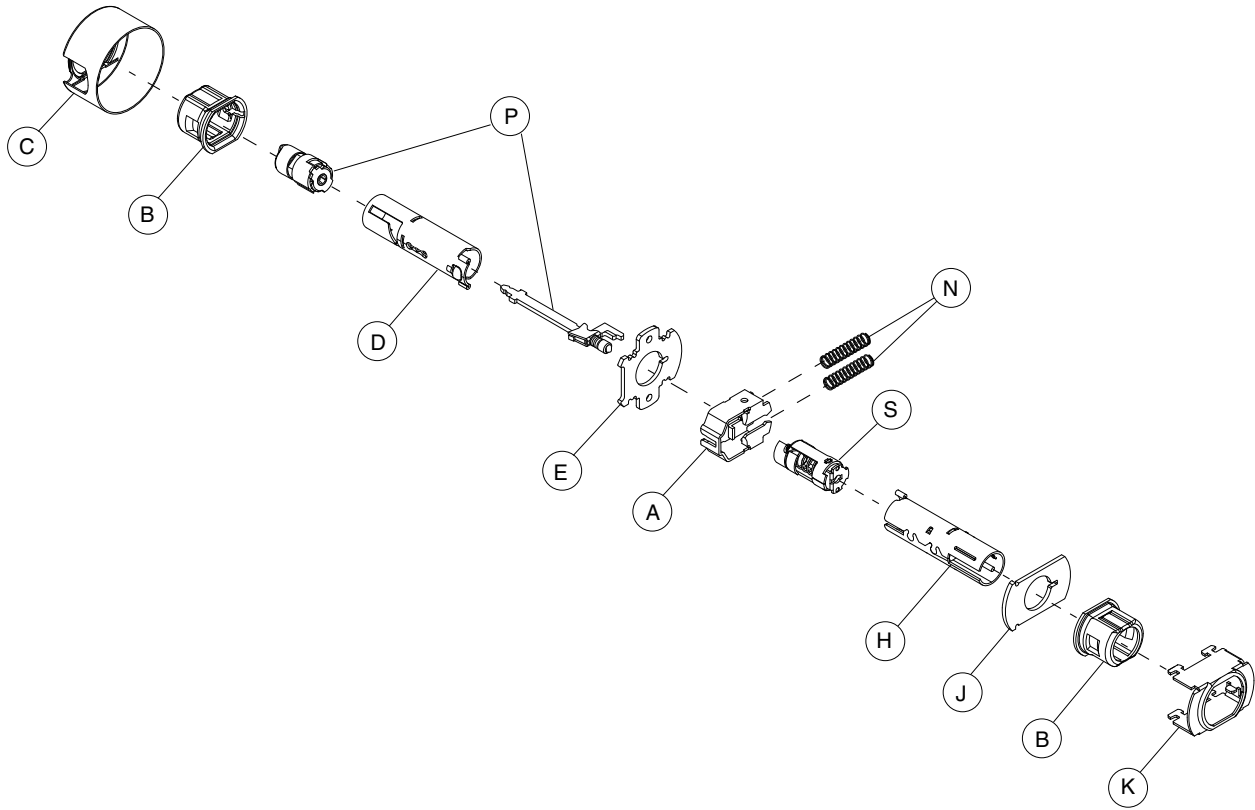

Letter	Description	Part no.
A	Slide, Non-Restoring *	A590-181
B	Hub	A700-046
C	Housing, Chassis	A700-057
D	Spindle and Catch, Inside	A710-004
E	Plate, Hub, Inside	A501-305
H	Spindle and Catch, Outside	A710-001

Letter	Description	Part no.
J	Plate, Outside	A700-004
K	Frame, Hub	A700-056
N	Spring, Slide (2)	A501-311
P	Plunger and Button	51-037
S	Cam and Spring	A301-402

* AL53PD is available with restoring slide. Order by AL50PD x XA11-297.

Classroom Lock Chassis Assembly

AL70PD

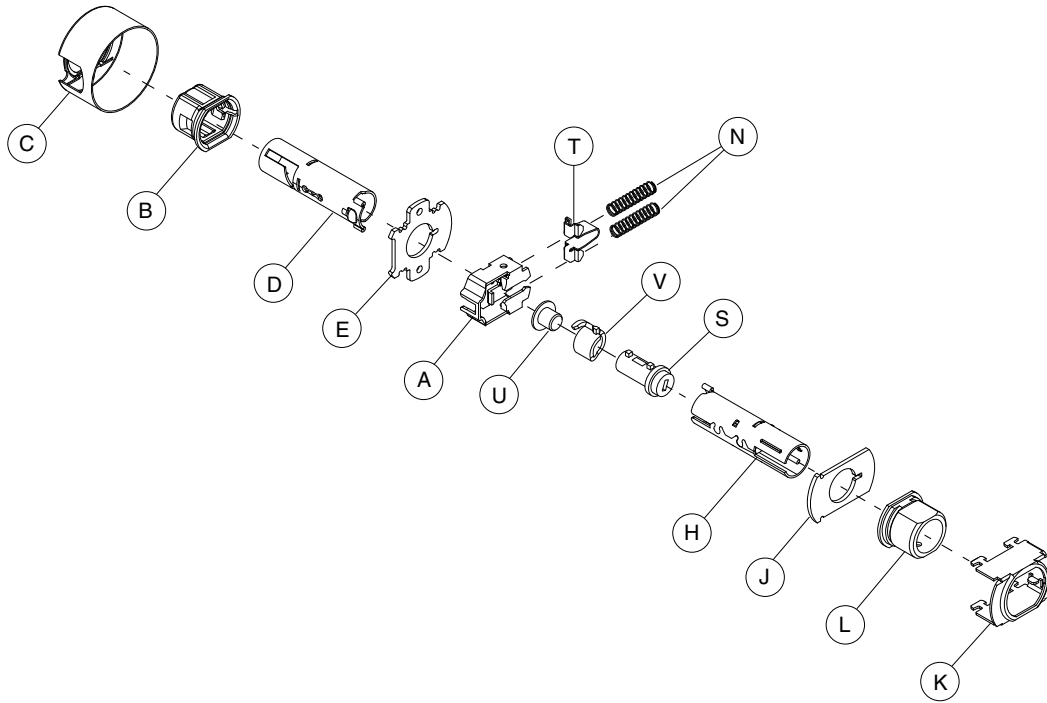

Letter	Description	Part no.
A	Slide, Non-Restoring	A590-159
B	Hub	A700-046
C	Housing, Chassis	A700-057
D	Spindle and Catch, Inside	A710-004
E	Plate, Hub, Inside	A501-305
H	Spindle and Catch, Outside	A710-001
J	Plate, Outside	A700-004

Letter	Description	Part no.
K	Frame, Hub	A700-056
L	Hub, AL70 Outside	A700-014
N	Spring, Slide (2)	A501-311
S	Plug, Cam	A501-721
T	Spring Seat	A508-597
U	Spacer, Cam	A501-791
V	Cam, Spiral	A700-017

Storeroom Lock Chassis Assembly

AL80PD

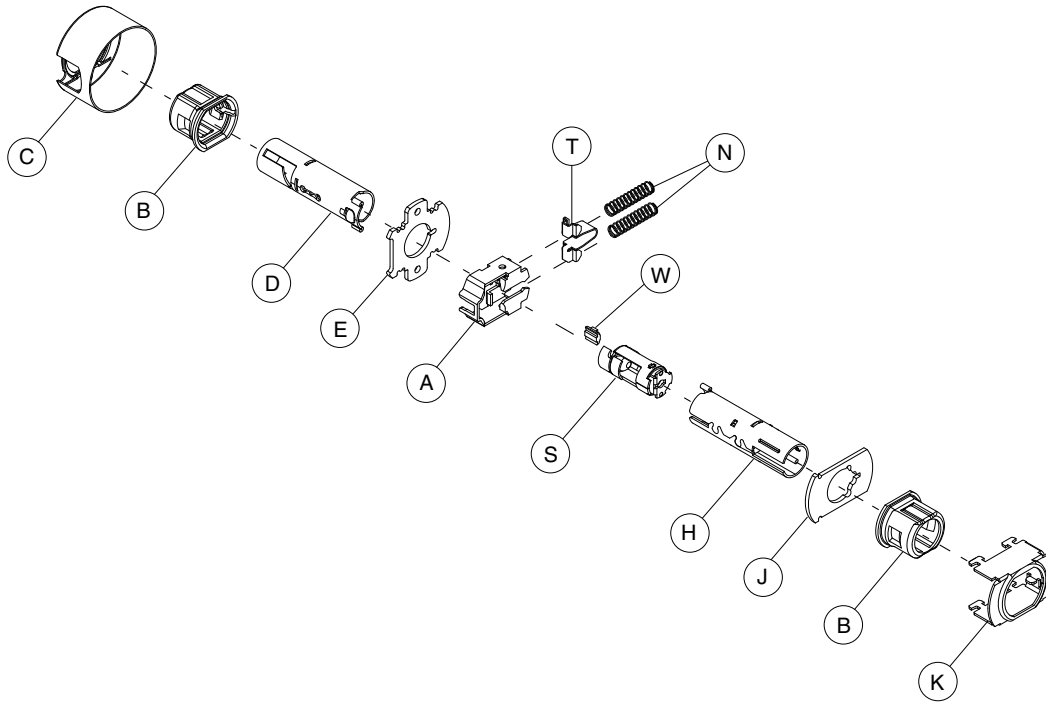

Letter	Description	Part no.
A	Slide, Non-Restoring	A590-159
B	Hub (2)w	A700-046
C	Housing, Chassis	A700-057
D	Spindle and Catch, Inside	A710-004
E	Plate, Hub, Inside	A501-305
H	Spindle and Catch, Outside	A710-001

Letter	Description	Part no.
J	Plate, Outside	A501-901
K	Frame, Hub	A700-056
N	Spring, Slide (2)	A501-311
S	Cam and Spring	A201-370
T	Spring Seat	A508-597
W	Wedge, Spindle	A501-615

Faculty Restroom Lock Chassis Assembly

AL85PD

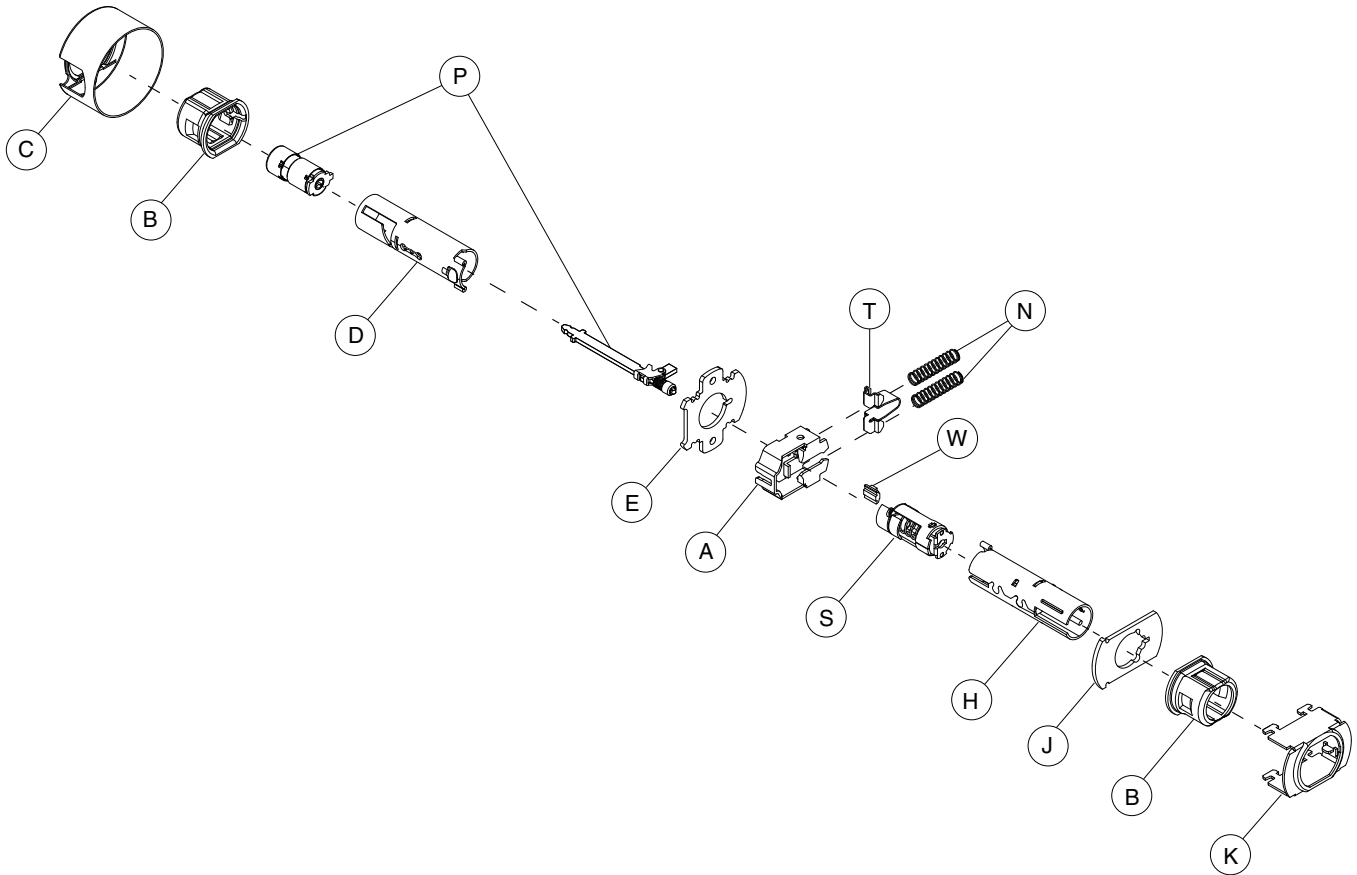

Letter	Description	Part no.
A	Slide, Restoring	A590-158
B	Hub	A700-046
C	Housing, Chassis	A700-057
D	Spindle and Catch, Inside	A710-004
E	Plate, Hub, Inside	A501-305
H	Spindle and Catch, Outside	A710-001
J	Plate, Outside	A501-901

Letter	Description	Part no.
K	Frame, Hub	A700-056
N	Spring, Slide (2)	A501-311
P	Plunger and Button	51-038
S	Cam and Spring	A301-402
T	Spring Seat	A508-597
W	Wedge, Spindle	A501-615

Latches

Latches

Part number		Backset	Housing diameter	Description
Springlatch	Deadlatch			
11-068	11-085	2 3/8"	7/8"	Square corner, 1" x 2 1/4"
11-069	11-088			1/4" radius round corner, 1" x 2 1/4"
11-110	11-104		1"	1" circular drive-in, (605 and 626 finish only)
11-111	11-091	2 3/4"	7/8"	Square corner, 1" x 2 1/4"
11-112	11-092			1/4" radius round corner, 1" x 2 1/4"
11-116	11-096		1"	Square corner, 1 1/8" x 2 1/4", standard
11-113	11-105			1" circular drive-in, (605 and 626 finish only)
11-118	11-103	3 3/4"	1"	Square corner, 1 1/8" x 2 1/4"

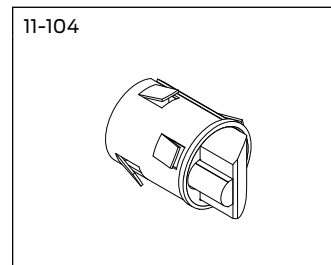
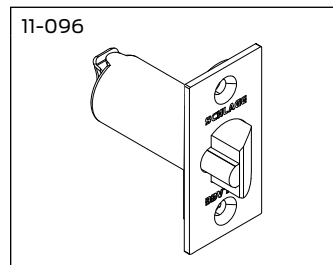
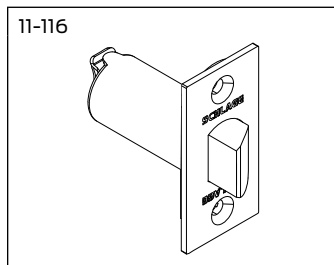

- ➔ Note: 2 3/8" backset latches require backset extension link 41-005. See "Latch Accessories and Adapters" below.
- ➔ Specify latch finish: 605, 606, 609, 612, 613, 619, 625, 626, 643.

Latch accessories and adapters

Part number	Description
37-001	Metal door reinforcement kit for 7/8" and 1" diameter housings. (Specify door thickness)
39-030 *	Adapts a square corner latch and a 2 3/4" high square corner strike to a 1/2" rabbeted door and frame preparation
41-005 **	5" Backset extension link (must be used with 2 1/8" backset latches)
A501-565	Reinforcement for non-reinforced metal doors 1 3/8" thick. Fits both 7/8" and 1" diameter housings
A501-566	Reinforcement for non-reinforced metal doors 1 3/4" thick. Fits both 7/8" and 1" diameter housings
A501-567	3 1/2" long latch housing sleeve, reinforcement for joint between latch and backset link, or to hold latch in metal doors
A501-878	Faceplate adapter to adapt 1" faceplate to 1 1/8" door preparation
G506-815	1" long latch housing sleeve to adapt 7/8" diameter housing to 1" latch bore

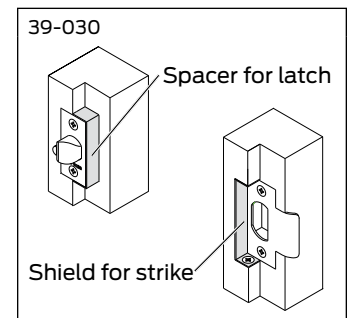
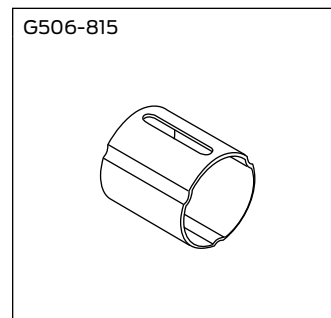
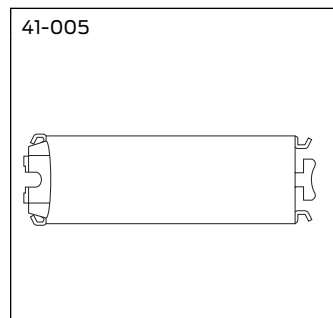
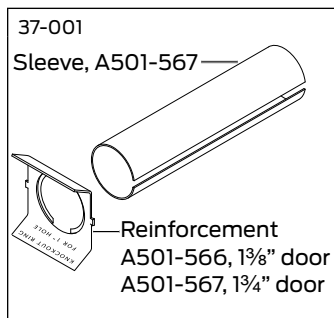

- * 39-030 Rabbeted latch and strike kit is available for Springlatch and Deadlatch applications. Available in 605 and 626 finish only.
- ** 41-005 requires: 1) reinforcement when used in hollow metal doors, and 2) one G506-815 sleeve when used with 1" latch holes.

Strikes

Part Number	Lip Length	Description
10-001	1", 1 $\frac{1}{8}$ ", 1 $\frac{1}{4}$ ", 1 $\frac{1}{2}$ ", 1 $\frac{3}{4}$ ", 2"	Square corner T-strike 1 $\frac{1}{8}$ " x 2 $\frac{3}{4}$ ", with strike box (specify lip length)
10-004	1 $\frac{1}{8}$ "	$\frac{1}{4}$ " radius round corner T-strike 1 $\frac{1}{8}$ " x 2 $\frac{3}{4}$ ", with strike box
10-025	1 $\frac{3}{16}$ "	ANSI 1 $\frac{1}{4}$ " x 4 $\frac{7}{8}$ ", standard, no box
	1 $\frac{3}{8}$ ", 1 $\frac{1}{2}$ "	ANSI 1 $\frac{1}{4}$ " x 4 $\frac{7}{8}$ ", no box (specify lip length)
10-026	1 $\frac{1}{8}$ "	Square corner, 1 $\frac{5}{8}$ " x 2 $\frac{1}{4}$ ", full lip, no box
10-027	1 $\frac{1}{8}$ "	$\frac{1}{4}$ " radius round corner, 1 $\frac{5}{8}$ " x 2 $\frac{1}{4}$ ", full lip, no box
10-058	1 $\frac{7}{32}$ "	Circular, adjustable 1 $\frac{3}{4}$ " diameter (605 and 626 finish only)
K510-066	–	Box for ANSI strike

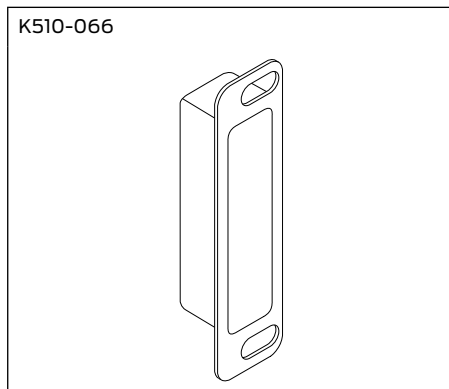
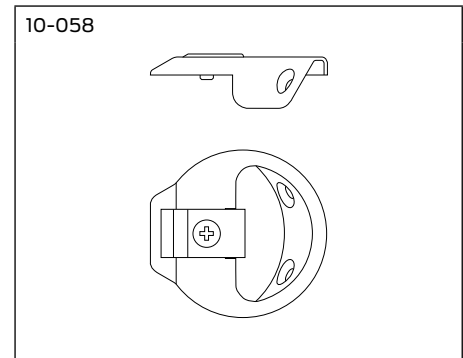
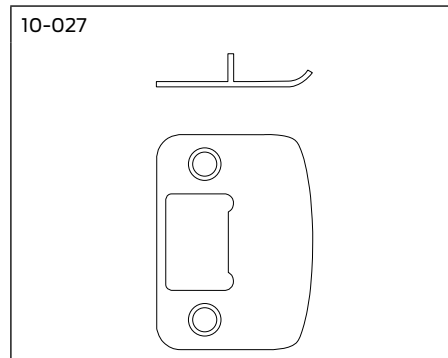
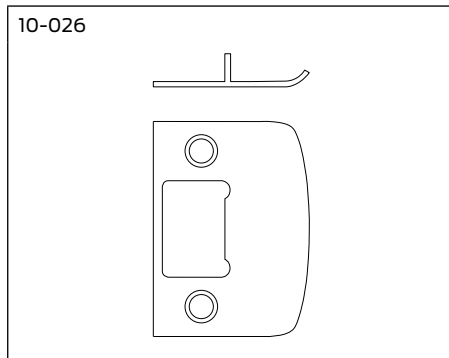
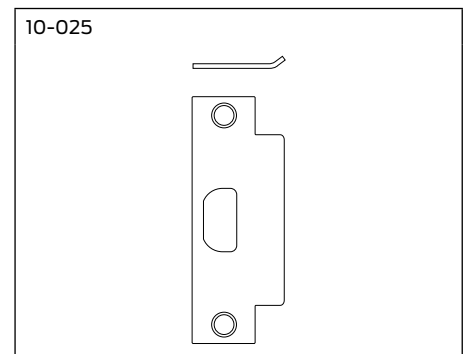
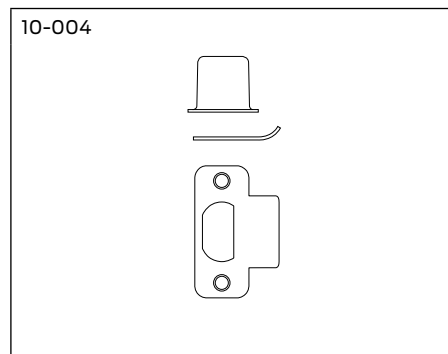
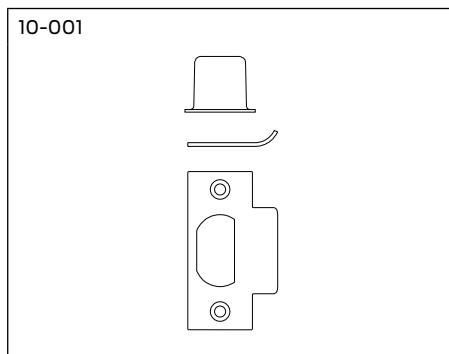

Specify strike finish: 605, 606, 609, 612, 613, 619, 625, 626, 643 (except 10-058 circular strike available in 605, 626 finish only)

Cylinder Options

Standard Cylinders

Standard cylinders are available in Classic keyway or patented Everest keyway. Specify keyway.

Functions	Cylinder Mechanism	Complete Cylinder
All functions except AL85	Conventional	21-020
	Primus	20-728
	Primus-XP	20-728-XP
	Primus UL437	20-528
	Primus UL437-XP	20-258-XP
AL85 Hotel/Motel Lock	Conventional	21-021

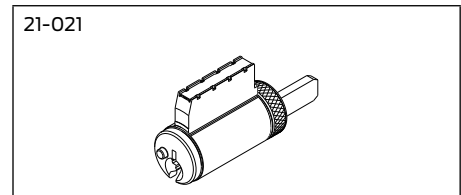
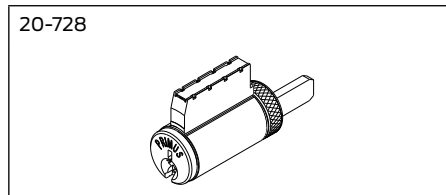
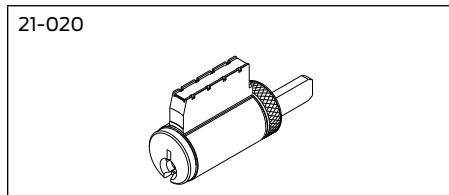

FSIC and SFIC Cylinders

Full Size Interchangeable Core (FSIC) cylinders are available for Saturn lever design and JD suffix locksets only. Locks are furnished 1-bitted with two 6-pin keys unless otherwise specified. FSIC cylinders may be integrated into any 5-pin or 6-pin Schlage key system.

Small Format Interchangeable Core (SFIC) cylinders are available for Saturn lever design and BD suffix locksets only. SFIC cylinders are for Schlage Everest B and Everest 29 R family restricted keyway cores. SFIC cylinders are compatible with Best®, Falcon and other competitive small format cores.

FSIC and SFIC cylinders are not available with Omega lever design, and not available with AL85 function .

Description	Part Number
FSIC Conventional core	23-030
FSIC Primus	20-740
FSIC Primus-XP	20-740-XP
SFIC Everest combined core	80-037
SFIC Everest uncombined core	80-036
SFIC Best keyway 7-pin uncombined core	80-033
SFIC Best keyway 6-pin uncombined core	80-043

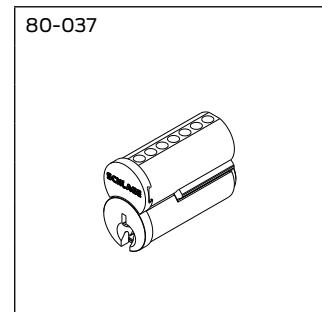
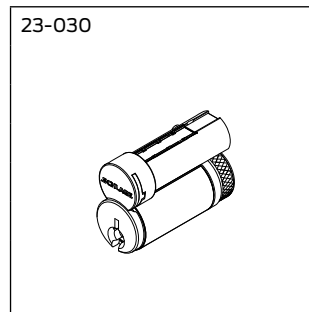

Cylinder Options

Full Size Interchangeable Core

Classic, Exploded View

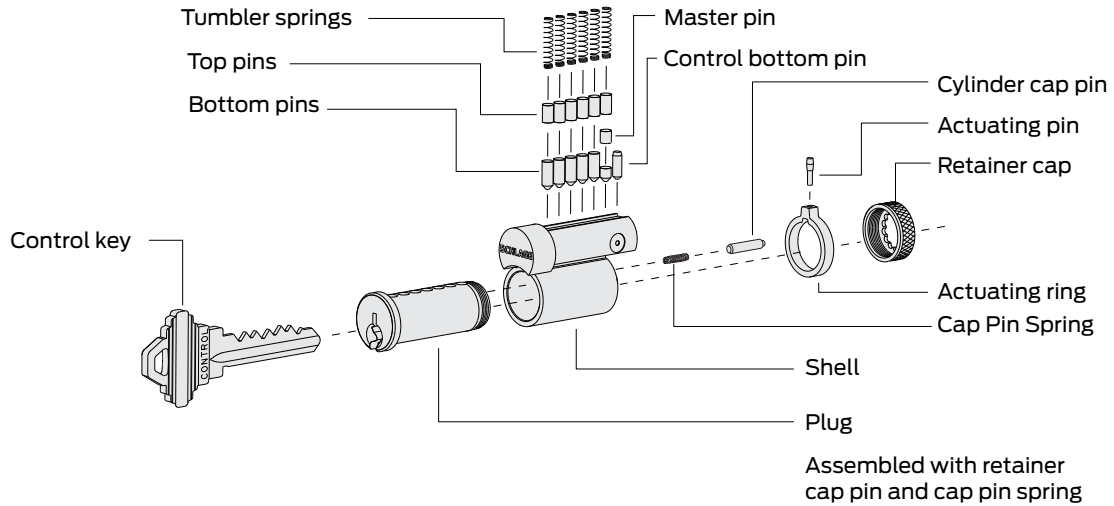

Full Size Interchangeable Core Parts

Description	Part Number
Cap pin spring	C503-115
Retainer cap	C503-118
Cylinder cap pin	C603-827

Description	Part Number
Actuating ring	C603-956
Actuating pin (control top pin)	C603-964
Control bottom pin	C603-967

Small Format Interchangeable Core

Everest, Exploded View

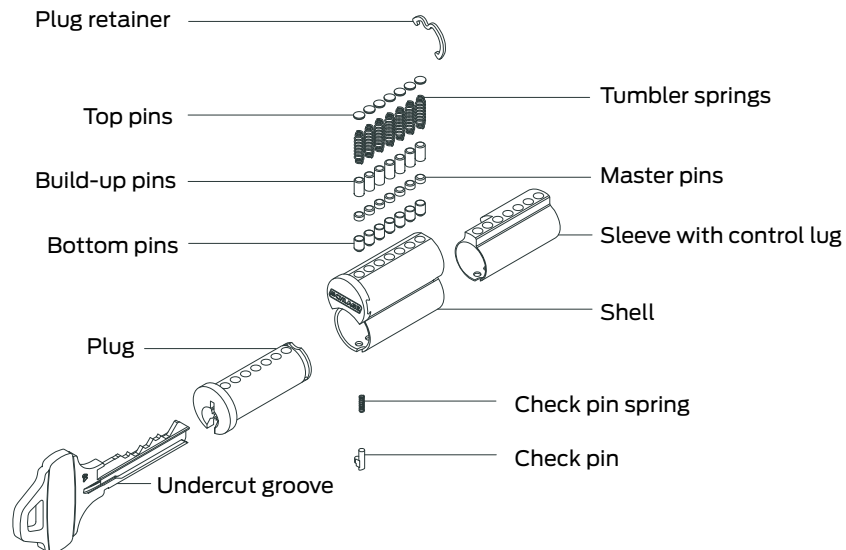

Cylinder Options

Interchangeable Core Related Parts and Levers

Description	Part Number
Full size core lever and lever insert	51-022
Full size core driver, universal	A700-052
Small format core lever and lever insert	51-024
Small format core retainer	A700-021
Small format core driver	C604-381
Small format core spacer	D500-000*
Small format core spindle and catch, outside (AL50, AL53, AL70, AL80)	A710-008
Lever insert, SFIC	A700-045
Lever insert, SFIC, 1 $\frac{3}{8}$ " - 1 $\frac{7}{8}$ " doors	A700-047**

* Two spacers required for 6-pin, one spacer required for 7-pin.

** For locks manufactured after March 2003.

Cylinder Conversion

(for part numbers, refer to list above)

Conventional Cylinder to FSIC

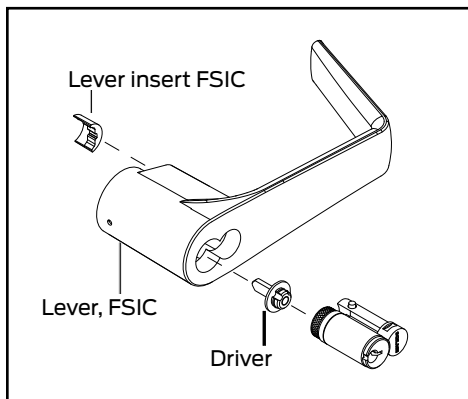

Conventional Cylinder to SFIC (requires chassis disassembly)

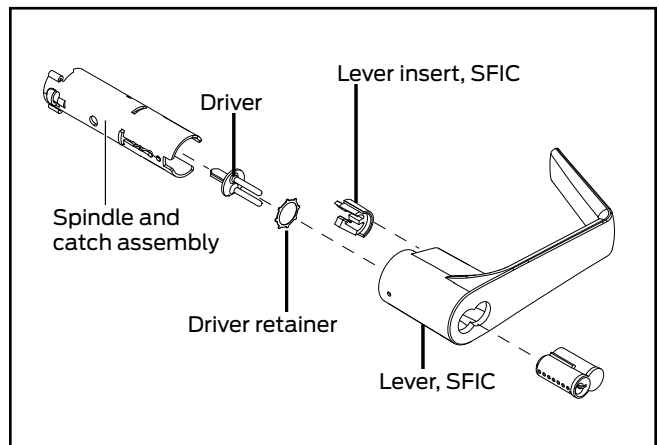

Parts

Parts

Parts for 2-Inch Doors

Part Number	Description
A700-043	Driver Bushing, 2-inch door (specify finish)
A700-028	Hub, 2-inch door, outside and inside, except AL25 and AL70 outside (for locks manufactured after May 2003) *
A700-029	Hub, 2-inch door, outside AL70 (for locks manufactured after May 2003) *
A700-030	Hub, 2-inch door, outside AL25
A700-033	Full size interchangeable core lever insert, 2-inch door
A700-034	Lever insert, 2-inch door

* For locks manufactured before May 2003, see "Hub, Frame and Housing Kits" below.

Hub, Frame and Housing Kits

for Locks Manufactured before May, 2003

Part Number	Function(s)	Door Thickness	Kit Contents	
A700-048	ALL except AL25 and AL70	1 ³ / ₈ " - 1 ⁷ / ₈ "	A700-046, Hub (2) A700-056, Frame, hub (1)	A700-057, Housing (1)
A700-050		2"	A700-056, Frame, hub (1) A700-028, Hub (2)	A700-057, Housing (1)
A700-049	AL70	1 ³ / ₈ " - 1 ⁷ / ₈ "	A700-056, Frame, hub (1) A700-046, Hub (1)	A700-014, Hub (1) A700-057, Housing (1)
A700-051		2"	A700-056, Frame, hub (1) A700-028, Hub (1)	A700-029, Hub (1) A700-057, Housing (1)

Plunger Units

Part Number	Description
51-037	Plunger unit, inside, AL53
51-038	Plunger unit, inside, AL85
51-039	Plunger unit, inside, AL40, AL44, AL50
51-040	Plunger unit, outside, AL40
51-041	Plunger unit, outside, AL44

Specify finish.

Screws and Screw Packs

Screws

Part Number	Description
A501-171	Washer, thru bolt, AL170, specify finish
A501-746	Mounting, thru bolt, AL170 (1/4"-20 x 2 1/2", POH machine screw), specify finish
C603-256	ANSI strike, (12-24 x 1", PFH combo screw), specify finish
C603-897	Latch and strike, (8-32 x 3/4", PFH combo screw), specify finish
C604-395	Spring cage, (8-32 x 2 1/8", PFH machine screw)
L583-133	Mounting, surface, AL170 (#8 x 1", sheet metal screw)

Screw Packs, Standard

Part Number	Description/Contents
B202-517	Latch and strike: C603-897 (4), specify finish
C203-736	ANSI strike: C603-256 (2), specify finish
C303-438	Spring cage: C604-395 (2)
C303-029	Mounting, all functions except AL170: C603-897 (4); C604-395 (2); C603-256 (2); M504-271 (1), specify finish
C303-421	Mounting, AL170: A501-167 (1); A501-171 (1); A501-746 (1); L583-133 (2); M504-271 (1), specify finish

Screw Packs, Torx

Part Number	Description/Contents
C203-311	Latch and strike: C503-766, T-15 (4), specify finish
C203-312	Latch and strike: C503-766, T-15 (2); L583-371, T-20 (2), specify finish

Note: Torx screw packs are furnished with appropriate T-xx installation tool(s).

Door Handing

All Schlage locks are reversible. Hand information should be specified to ensure proper cylinder orientation in keyed functions, and to ensure proper finish of latchbolt and strike for locks to be installed on reverse bevel doors. Use the diagram below to correctly determine the hand of the door.

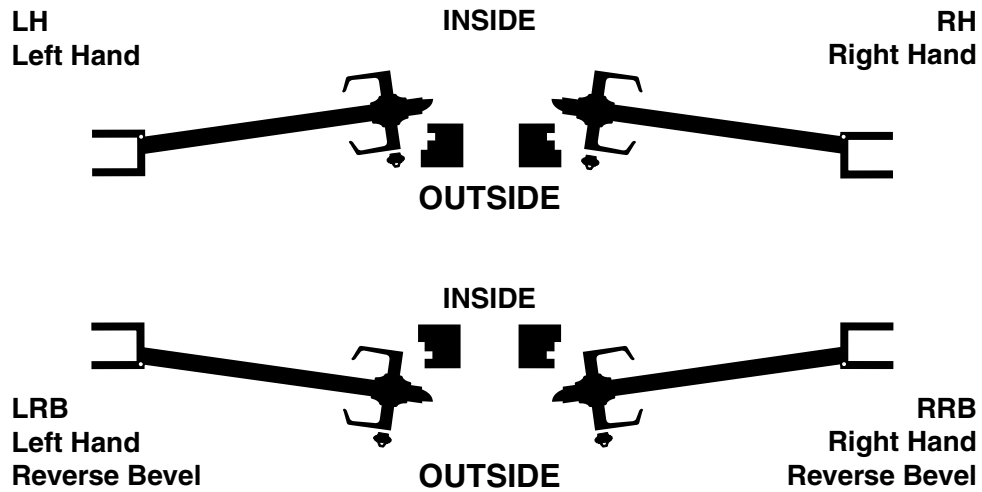

Ordering Procedure

To order Schlage products, descriptive data should be in the same sequence as shown below.

Line Item	Qty	Product	Outside		Inside		Hand	Latch	Strike	Dr Thk	Ext	Dim	Additional Details
			DES	FIN	DES	FIN							
1	2	3	4	5	6	7	8	9	10	11	12	13	14

Line Item:	Line item number
Qty:	Quantity
Product:	Complete lock product or part number
Outside DES:	Outside design code
Outside FIN:	Outside finish code
Inside DES:	Inside design code
Inside FIN:	Inside finish code
Hand:	Hand of door: Only one hand allowed per line item. Example: RH=right hand, LH=left hand, RR=right reverse, LH=left reverse
Latch:	Leave blank for standard latch or specify part number if non-standard latch is required
Strike:	Leave blank for standard strike or specify part number if non-standard latch is required. LLL=less strike
Dr Thk:	Door thickness: Enter door thickness if non-standard, example 138=1 ³ / ₈ ", 214=2 ¹ / ₄ ", 212=2 ¹ / ₂ " (EI or EO assumes the latch will be centered on 1" door, to which material has been added)
Ext:	Extension: Enter one of the following when door 2" thick or greater are specified: EE=extended equally, EI=extended inside, EO=extended outside, ED=extended differently
Dim:	Dimension: Enter dimension for non-standard strike lip length and mortise cylinder or blocking ring length
Additional Details:	Enter detail for keying information and for special requirements.

Limited Warranty

Schlage Lock Company (the "Company") extends a three-year limited warranty from the original date of purchase to the Original User of the products manufactured by the Company (the "Product") against defects in material and workmanship. Certain Products contain restrictions to this limited warranty, additional warranties or different warranty periods. Please see below for specific Product warranty information.

The provisions of this warranty do not apply to Products:(i) used for purposes for which they are not designed or intended; (ii) which have been subjected to alteration, abuse, misuse, negligence or accident; (iii) which have been improperly stored, installed, maintained or operated; (iv) which have been used in violation of written instructions provided by Schlage; (v) which have been subjected to improper temperature, humidity or other environmental conditions (i.e., corrosion); or (vi) which, based on Schlage's examination, do not disclose to Schlage's satisfaction non-conformance to the warranty. Additionally, Schlage will not warrant ANSI A156.2 Grade 2 lever Product installed in educational facilities and student housing.

Specific Product Warranty Restrictions / Additional Warranties

Small Format Interchangeable Core (SFIC) Warranty: This limited warranty also applies to Schlage locks and housings when used with another manufacturer's cores, or to Schlage cores (i.e. SFIC) when used in another manufacturer's locks and housings. The use of unauthorized cylinder cams or other components with the Products shall void this warranty.

Everest® Primus® Limited Lifetime Key Breakage Warranty:A limited lifetime warranty is provided to the Original User against key breakage, subject to the restrictions of this limited warranty.

About Allegion

Allegion (NYSE: ALLE) creates peace of mind by pioneering safety and security. As a \$2 billion provider of security solutions for homes and businesses, Allegion employs more than 7,800 people and sells products in more than 120 countries across the world. Allegion comprises 23 global brands, including strategic brands CISA®, Interflex®, LCN®, Schlage® and Von Duprin®.

For more, visit www.allegion.com.

aptiQ ■ LCN ■ **SCHLAGE** ■ STEELCRAFT ■ VON DUPRIN